

INSTRUCTION MANUAL

Smartzoom 100



Version: 1.0 (April 2025)



Content

1 Safety

1.1 Intended use

1.2 Warnings

2 Assembling your microscope

2.1 Assembly

2.2 Connecting

2.3 Power on

2.4 Changing objectives

2.5 Using the magnetic ring light

3 Control options

3.1 Controller

3.2 Keyboard

3.3 Foot switch

3.4 Mouse

3.5 Open API

4 Menu

4.1 Graphical user interface

4.2 Menu features

4.2.1 Light

4.2.2 Applications

4.2.2.1 Ruler app

4.2.2.2 Measurement app

4.2.3 Favourite shortcuts

4.2.4 Settings

4.2.4.1 Settings - General

4.2.4.3 Settings - Network

4.2.4.3 Settings - Camera

4.2.5 Power controls

5 Other features

5.1 File share

6 Maintenance & support

6.1 Taking care of your microscope

6.2 Warranty

6.3 Troubleshooting

6.4 Support

6.5 Technical specifications

6.6 Declaration of conformity

7 Notes

1 Safety

To ensure proper and safe usage of the Smartzoom 100, please read the Intended use and Warnings section closely before starting the assembly and usage of the product.

1.1 Intended use

The product described in this manual is a digital magnifying system designed for manual visual inspection. If you have any questions about how to use the product or experience any use cases that are not described in this product manual, we refer to section 6.3.

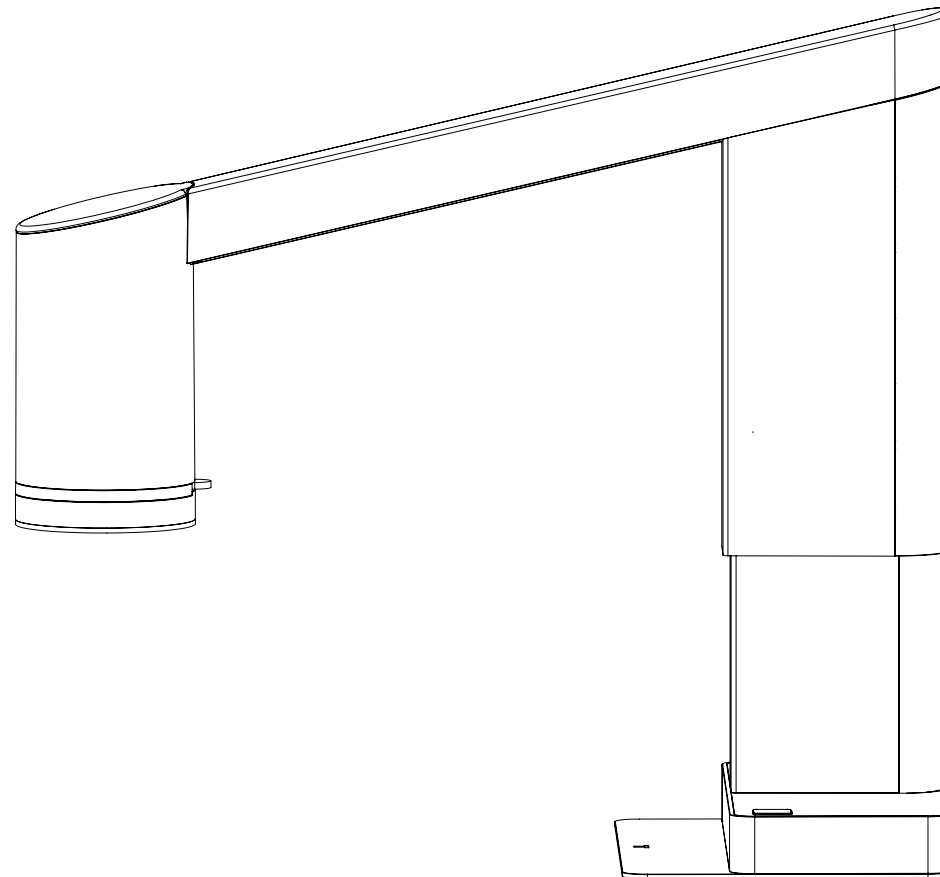

1.2 Warnings



- Read all safety information before you use the product.
- Please pay attention when you see a warning label on the product.



- This product is for indoor use only.



- You must not discard this electrical/electronic product in domestic household waste. Please dispose at your local recycling centre.

- Read the manual before you use the product.
- Use the product only as specified, or the protection supplied by the product can be compromised.
- Do not position the equipment so that it is difficult to operate the disconnecting device (appliance inlet of external power supply, equipment input connector).
- If fluids are spilled on the product, turn the system off immediately by pulling the power supply out of the electrical outlet.
- In case of fire close to the product, please turn off and disconnect the system.

- Avoid subjecting the objective to sharp or hard objects.
- Do not connect the product, if visible damages appear.
- Do not dismantle any parts of the product, except where noted in the manual.
- Never disassemble or clean internal optical surfaces.
- Use only the power supply provided by ZEISS.
- Always turn off the system before unplugging, when possible.
- Lift/carry the base with both hands when the microscope is unassembled.

- To prevent pinch injuries during assembly of the arm and base, keep one hand on the horizontal arm on which the camera head is mounted and use the other to close the hatch on the base.
- When moving the assembled microscope, keep one hand on the vertical arm attached to the base and the other on the horizontal arm on which the camera head is mounted.

Content

1 Safety

1.1 Intended use

1.2 Warnings

2 Assembling your microscope

2.1 Assembly

2.2 Connecting

2.3 Power on

2.4 Changing objectives

2.5 Using the magnetic ring light

3 Control options

3.1 Controller

3.2 Keyboard

3.3 Foot switch

3.4 Mouse

3.5 Open API

4 Menu

4.1 Graphical user interface

4.2 Menu features

4.2.1 Light

4.2.2 Applications

4.2.2.1 Ruler app

4.2.2.2 Measurement app

4.2.3 Favourite shortcuts

4.2.4 Settings

4.2.4.1 Settings - General

4.2.4.3 Settings - Network

4.2.4.3 Settings - Camera

4.2.5 Power controls

5 Other features

5.1 File share

6 Maintenance & support

6.1 Taking care of your microscope

6.2 Warranty

6.3 Troubleshooting

6.4 Support

6.5 Technical specifications

6.6 Declaration of conformity

7 Notes

2 Assembling your microscope

Assembling and installing the Smartzoom 100 requires no extra tools and everything you need is included in your delivery.

2.1 Assembly

- Open hatch and tilt arm forward to place it in the base.
- Tilt arm upright before closing the hatch. Be careful with the protruding PCB when tilting the arm upright.

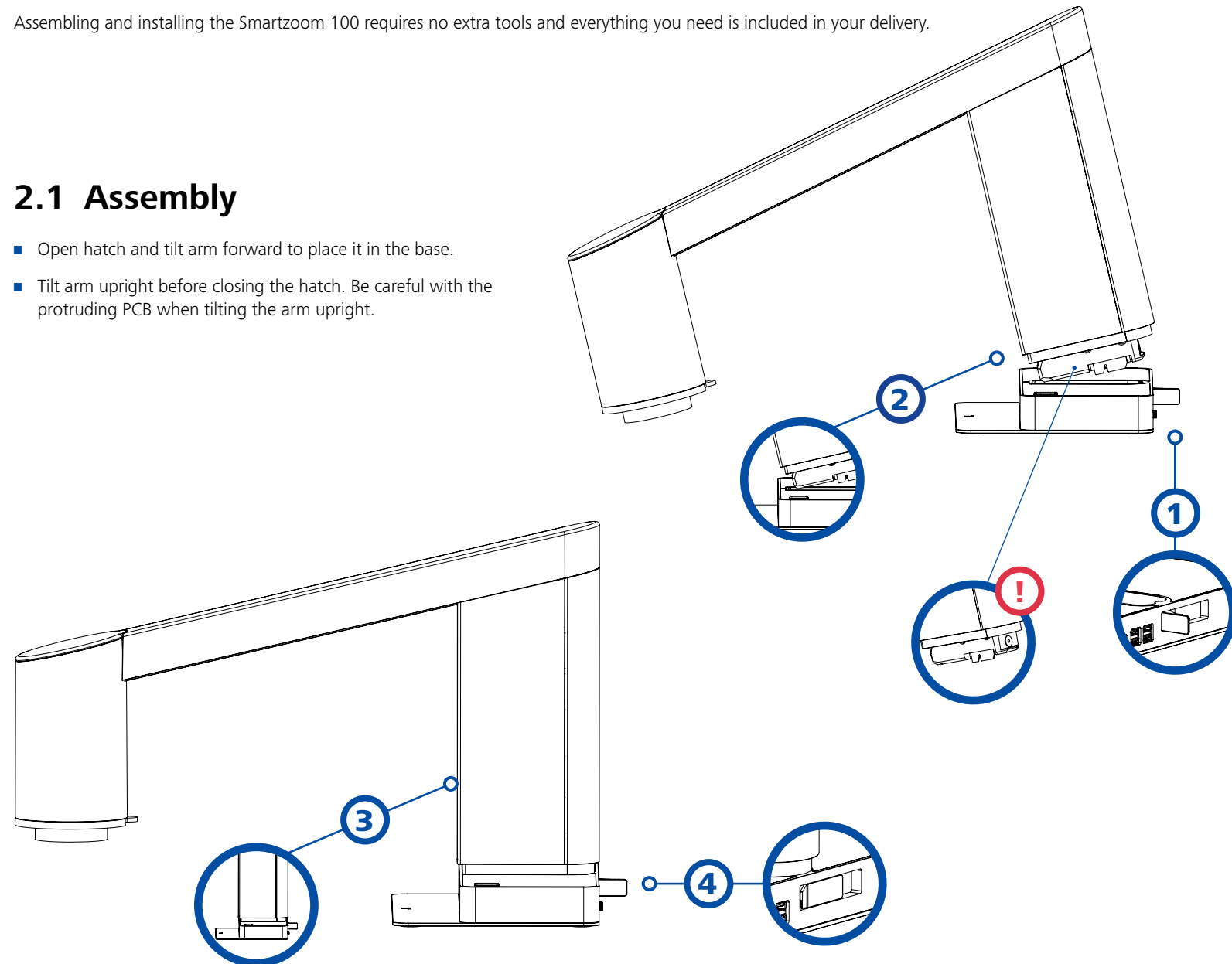

2.2 Connecting

Connect the cables as shown here.

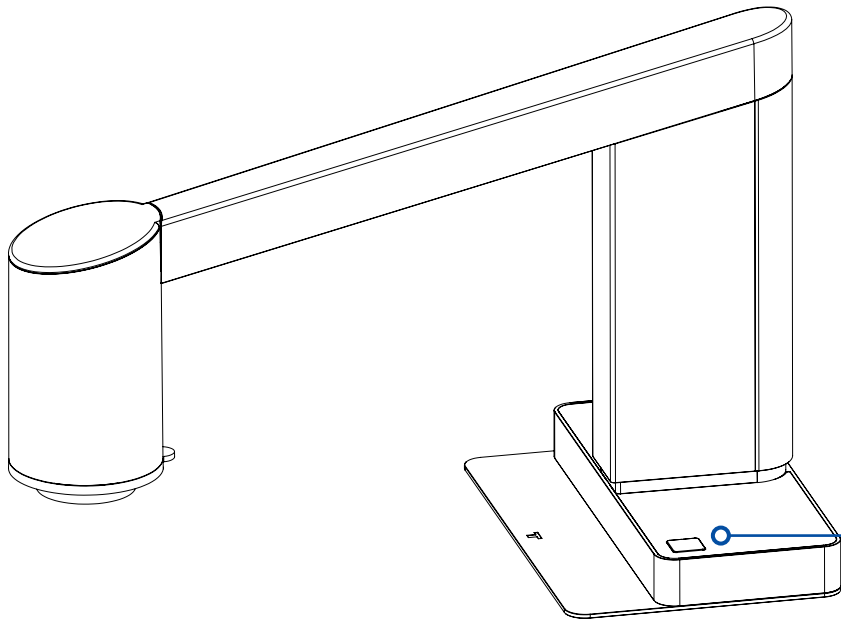
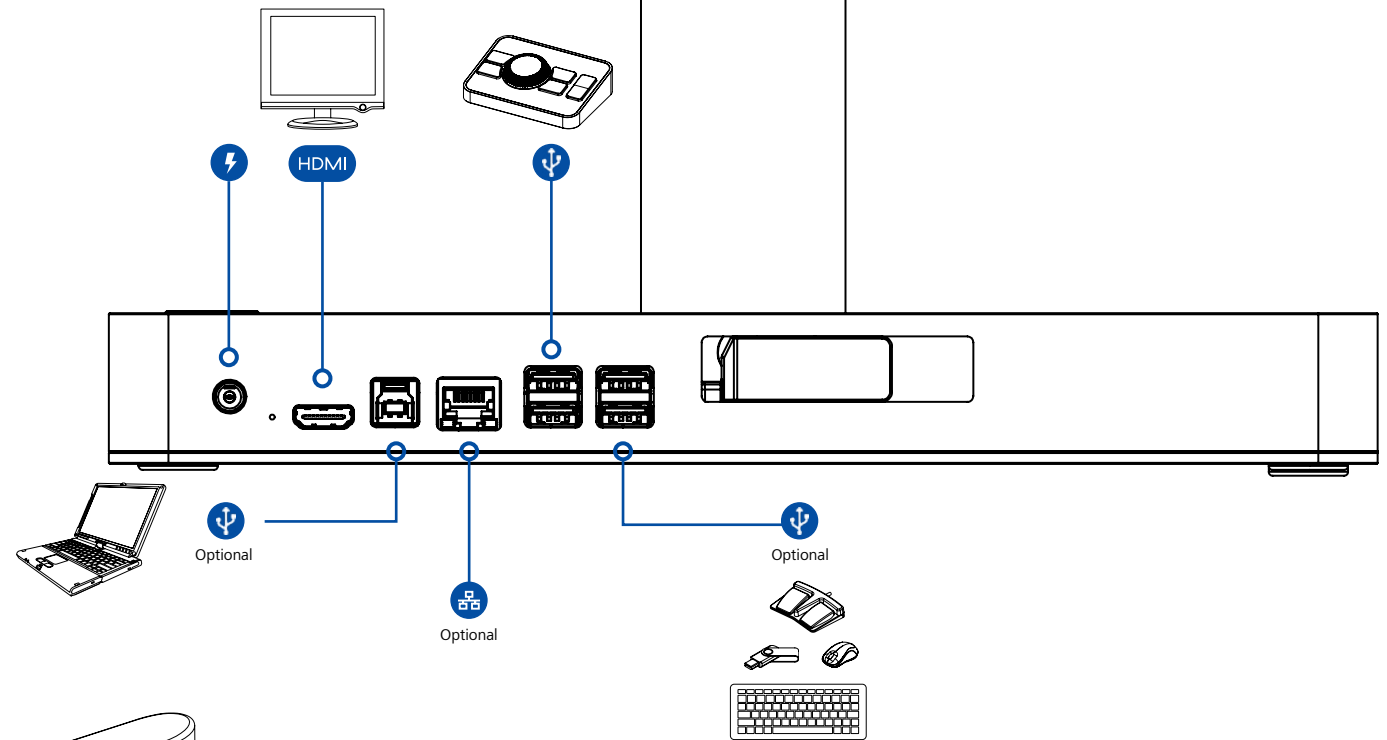

2.3 Power on

- Press button on the microscope base when it lights up.

Content

1 Safety

- 1.1 Intended use
- 1.2 Warnings

2 Assembling your microscope

- 2.1 Assembly
- 2.2 Connecting
- 2.3 Power on
- 2.4 Changing objectives
- 2.5 Using the magnetic ring light

3 Control options

- 3.1 Controller
- 3.2 Keyboard
- 3.3 Foot switch
- 3.4 Mouse
- 3.5 Open API

4 Menu

- 4.1 Graphical user interface
- 4.2 Menu features
 - 4.2.1 Light
 - 4.2.2 Applications
 - 4.2.2.1 Ruler app
 - 4.2.2.2 Measurement app
 - 4.2.3 Favourite shortcuts
 - 4.2.4 Settings
 - 4.2.4.1 Settings - General
 - 4.2.4.3 Settings - Network
 - 4.2.4.3 Settings - Camera
 - 4.2.5 Power controls

5 Other features

- 5.1 File share

6 Maintenance & support

- 6.1 Taking care of your microscope
- 6.2 Warranty
- 6.3 Troubleshooting
- 6.4 Support
- 6.5 Technical specifications
- 6.6 Declaration of conformity

7 Notes

2.4 Changing objectives

When removing an objective from the microscope, make sure to pull downwards on the tongue of the objective ring instead of gripping the objective itself.

To mount an objective, simply hold the objective ring close to the camera and the magnets will make sure that the objective is mounted correctly.

Mounting order

Mount the objective first before stacking the magnetic ring light on top.

This also means that you need to remove the Magnetic ring light before changing objectives.

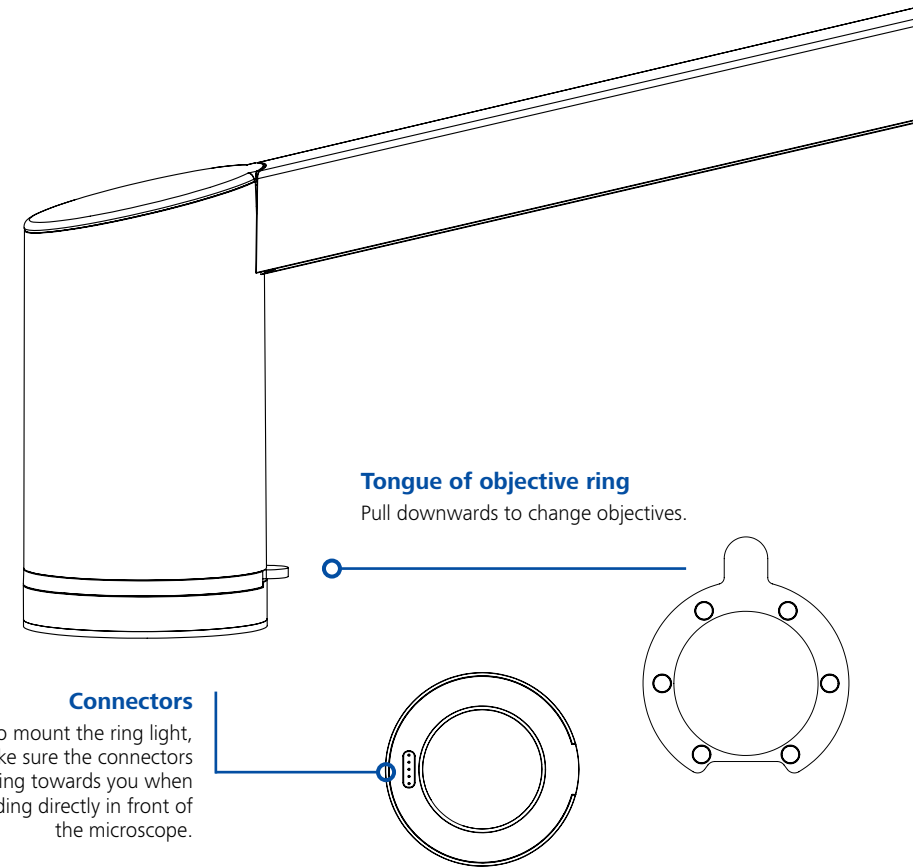

2.5 Using the magnetic ring light

If additional light is needed, mount the magnetic ring light on top of the objective and make sure to adjust the integrated carrier height by hand, so the ring light aligns with the bottom of the mounted objective. This prevents shadows and ensures the best lighting conditions.

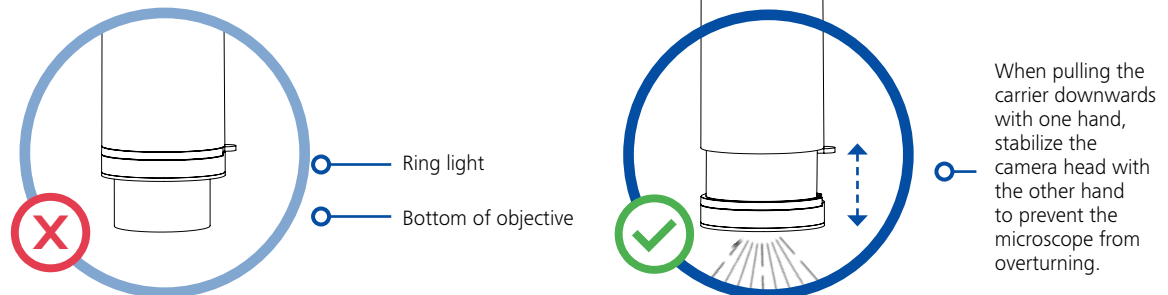

3 Control options

In this section, you'll learn the different control options for your microscope.

3.1 Controller

The centerpiece of the included Controller is a tactile wheel button, that makes menu navigation seamless and intuitive.

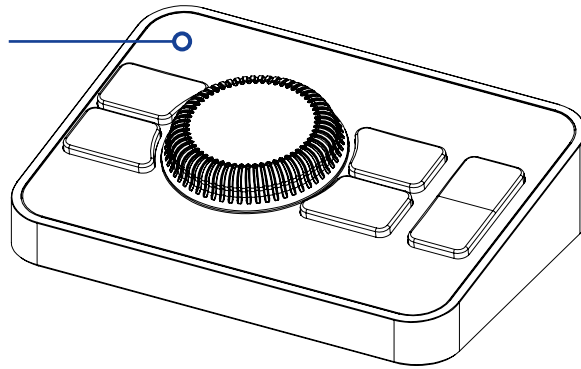

3.1.1 Connect to microscope

Connect the Controller to the microscope with its USB 2.0 cable via one of the four ports.

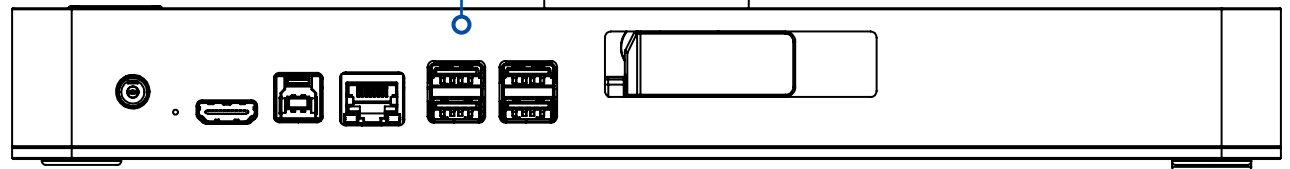

Content

1 Safety

1.1 Intended use

1.2 Warnings

2 Assembling your microscope

2.1 Assembly

2.2 Connecting

2.3 Power on

2.4 Changing objectives

2.5 Using the magnetic ring light

3 Control options

3.1 Controller

3.2 Keyboard

3.3 Foot switch

3.4 Mouse

3.5 Open API

4 Menu

4.1 Graphical user interface

4.2 Menu features

4.2.1 Light

4.2.2 Applications

4.2.2.1 Ruler app

4.2.2.2 Measurement app

4.2.3 Favourite shortcuts

4.2.4 Settings

4.2.4.1 Settings - General

4.2.4.3 Settings - Network

4.2.4.3 Settings - Camera

4.2.5 Power controls

5 Other features

5.1 File share

6 Maintenance & support

6.1 Taking care of your microscope

6.2 Warranty

6.3 Troubleshooting

6.4 Support

6.5 Technical specifications

6.6 Declaration of conformity

7 Notes

3.1.2 How to use the Controller

Select/Confirm or Toggle focus mode

Short press

Select/confirm selection (when menu is open).

Long press

Toggle between Autofocus and Manual focus mode (when menu is closed).

Image capture

Short press

Take image without graphics.

Long press

Take image with graphics.

Back

Navigate back in menu (when menu is open).

Menu

Open/exit menu.

Adjustment microscope height

Move microscope up or down.

Navigate menu / control zoom

- Rotate button to navigate through the menu when open.
- Rotate button to zoom in and out (when the menu is closed).

Go to Favourite menu

Quick access to user configured menu with short cut to favourite apps, functions and presets.



3.2 Keyboard

You can also control the microscope using any USB connected keyboard. The keyboard can either replace or be used alongside the Controller.

3.2.1 How to use the keyboard

Function (Shortcut)	Available when
<ul style="list-style-type: none"> Image capture without graphics (Ctrl & S) 	Always
<ul style="list-style-type: none"> Image capture with graphics (Ctrl & Shift & S) 	Always
<ul style="list-style-type: none"> Adjust microscope height (Alt & ↑ / ↓) 	Always
<ul style="list-style-type: none"> Perform a White Balance Calibration (WBC) (Ctrl & W) 	When in Manual WB mode
<ul style="list-style-type: none"> Activate presets 1-10 (Key 0-9, 0 activates Preset 10) 	If you've saved any presets
<ul style="list-style-type: none"> Change Focus mode (Ctrl & F) 	Always
<ul style="list-style-type: none"> Change between Dark and Light theme (Ctrl & T) 	Always
<ul style="list-style-type: none"> Zoom in/out - option 1 (Ctrl & ↑ / ↓) 	When in Autofocus mode
<ul style="list-style-type: none"> Zoom in/out - option 2 (Ctrl & Alt & ↑ / ↓) 	When in Manual focus mode
<ul style="list-style-type: none"> Adjust focus (Ctrl & ↑ / ↓) 	When in Manual focus mode

Shortcuts

Different shortcuts can be used at different times depending on whether the menu is open or closed, the active focus mode and if certain settings have been selected beforehand.

Please also note that the ↑ / ↓ keys and + / - keys have the same function. To keep the overview below as simple as possible, it only shows the ↑ / ↓ shortcuts.

Function (Shortcut)	Available when
<ul style="list-style-type: none"> Open menu (→ / Space / Enter) 	When menu is closed
<ul style="list-style-type: none"> Navigate menu (← / ↑ / ↓ / →) 	When menu is open
<ul style="list-style-type: none"> Confirm / Select (Space / Enter) 	When menu is open
<ul style="list-style-type: none"> Adjust value - option 1 (↑ / ↓) 	When value change menu is active on vertical menus
<ul style="list-style-type: none"> Adjust value - option 2 (← / →) 	When value change menu is active on horizontal menus
<ul style="list-style-type: none"> Close menu (Escape) 	Always
<ul style="list-style-type: none"> Abort value change in non-real-time changes (Escape) 	When value change menu is active
<ul style="list-style-type: none"> Activate/deactivate Ruler (Ctrl & R) 	Always
<ul style="list-style-type: none"> Go back (Backspace / ←) 	When menu is open, except when text input is selected

Content

1 Safety

1.1 Intended use

1.2 Warnings

2 Assembling your microscope

2.1 Assembly

2.2 Connecting

2.3 Power on

2.4 Changing objectives

2.5 Using the magnetic ring light

3 Control options

3.1 Controller

3.2 Keyboard

3.3 Foot switch

3.4 Mouse

3.5 Open API

4 Menu

4.1 Graphical user interface

4.2 Menu features

4.2.1 Light

4.2.2 Applications

4.2.2.1 Ruler app

4.2.2.2 Measurement app

4.2.3 Favourite shortcuts

4.2.4 Settings

4.2.4.1 Settings - General

4.2.4.3 Settings - Network

4.2.4.3 Settings - Camera

4.2.5 Power controls

5 Other features

5.1 File share

6 Maintenance & support

6.1 Taking care of your microscope

6.2 Warranty

6.3 Troubleshooting

6.4 Support

6.5 Technical specifications

6.6 Declaration of conformity

7 Notes

3.3 Foot switch

When used with the microscope, Foot Switch enables hands-free control over magnification, manual focus and photo capture.

3.3.1 Connect to microscope

Connect the Foot switch to the microscope with its USB 2.0 cable to any of the four ports.

3.3.2 How to use the Foot switch

Insert foot switch cable in one of the four ports.

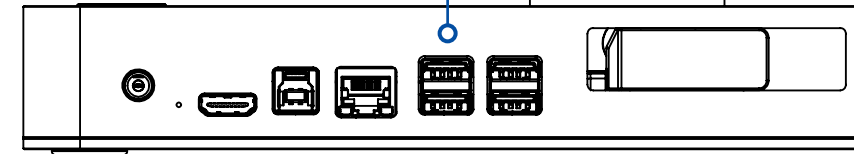

Take picture with graphics

Top button.

Zoom in or move focus up

- Left button to zoom in (when in Autofocus mode).
- Control manual focus to focus on objects closer to the objective (when in Manual focus mode).

Zoom out or move focus down

- Right button to zoom out (when in Autofocus mode).
- Control manual focus to focus on objects further away from to the objective (when in Manual focus mode).

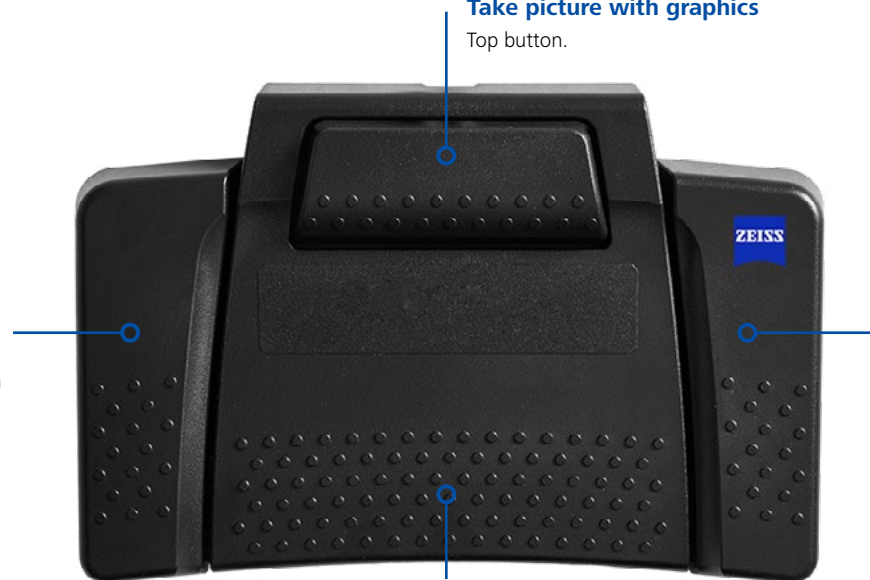

Take picture without graphics

Bottom button.

3.4 Mouse

You can also control selected features on the microscope using a USB connected mouse.

3.4.1 How to use the mouse

Control zoom / manual focus

- Scroll wheel to zoom in/out (when menu is closed).
- Control manual focus (when in Manual focus mode).

Change focus mode

Click wheel to change between Autofocus and Manual focus mode (when menu is closed).

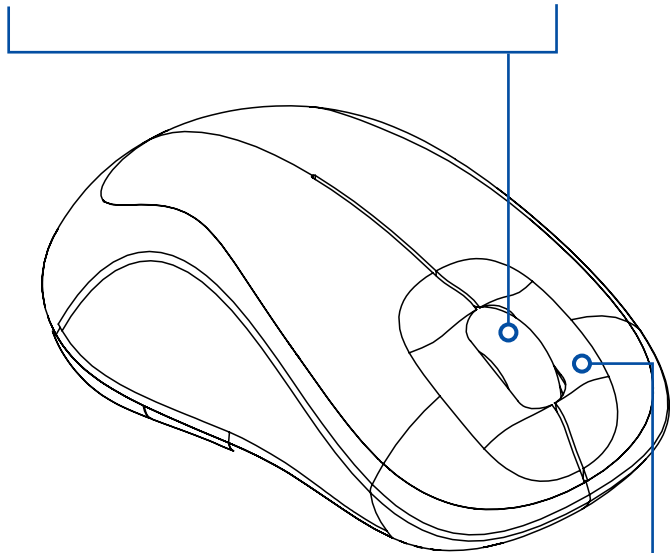

Confirm/Select

Left click to confirm or select (when menu is open).

3.5 Open API

Below, you can see a few examples of how to use the Open API to integrate your microscope with other systems or applications. This is a cost effective way to create a customized solution without the involvement of ZEISS.

Examples

Description

- | Examples | Description |
|--|--|
| ■ Control the microscope from anywhere | When the microscope is switched on, you can control it remotely using the Open API. |
| ■ Use microscope live image on AI platform | Use your own AI platform to change the settings on the microscope via the Open API. |
| ■ Collaborate with in-line robots | If you've mounted a microscope on an in-line robot, you can use the Open API to control the settings of the microscope, e.g. with presets, to capture high quality images. |

Content

1 Safety

- 1.1 Intended use
- 1.2 Warnings

2 Assembling your microscope

- 2.1 Assembly
- 2.2 Connecting
- 2.3 Power on
- 2.4 Changing objectives
- 2.5 Using the magnetic ring light

3 Control options

- 3.1 Controller
- 3.2 Keyboard
- 3.3 Foot switch
- 3.4 Mouse
- 3.5 Open API

4 Menu

4.1 Graphical user interface

4.2 Menu features

- 4.2.1 Light
- 4.2.2 Applications
 - 4.2.2.1 Ruler app
 - 4.2.2.2 Measurement app
- 4.2.3 Favourite shortcuts
- 4.2.4 Settings
 - 4.2.4.1 Settings - General
 - 4.2.4.3 Settings - Network
 - 4.2.4.3 Settings - Camera
- 4.2.5 Power controls

5 Other features

5.1 File share

6 Maintenance & support

- 6.1 Taking care of your microscope
- 6.2 Warranty
- 6.3 Troubleshooting
- 6.4 Support
- 6.5 Technical specifications
- 6.6 Declaration of conformity

7 Notes

4 Menu

Here's how to use the information shown in the graphical user interface on top of the microscope live image. Please note that the interface will differ depending on the software version on your microscope.

4.1 Graphical user interface

1. Closed menu icon

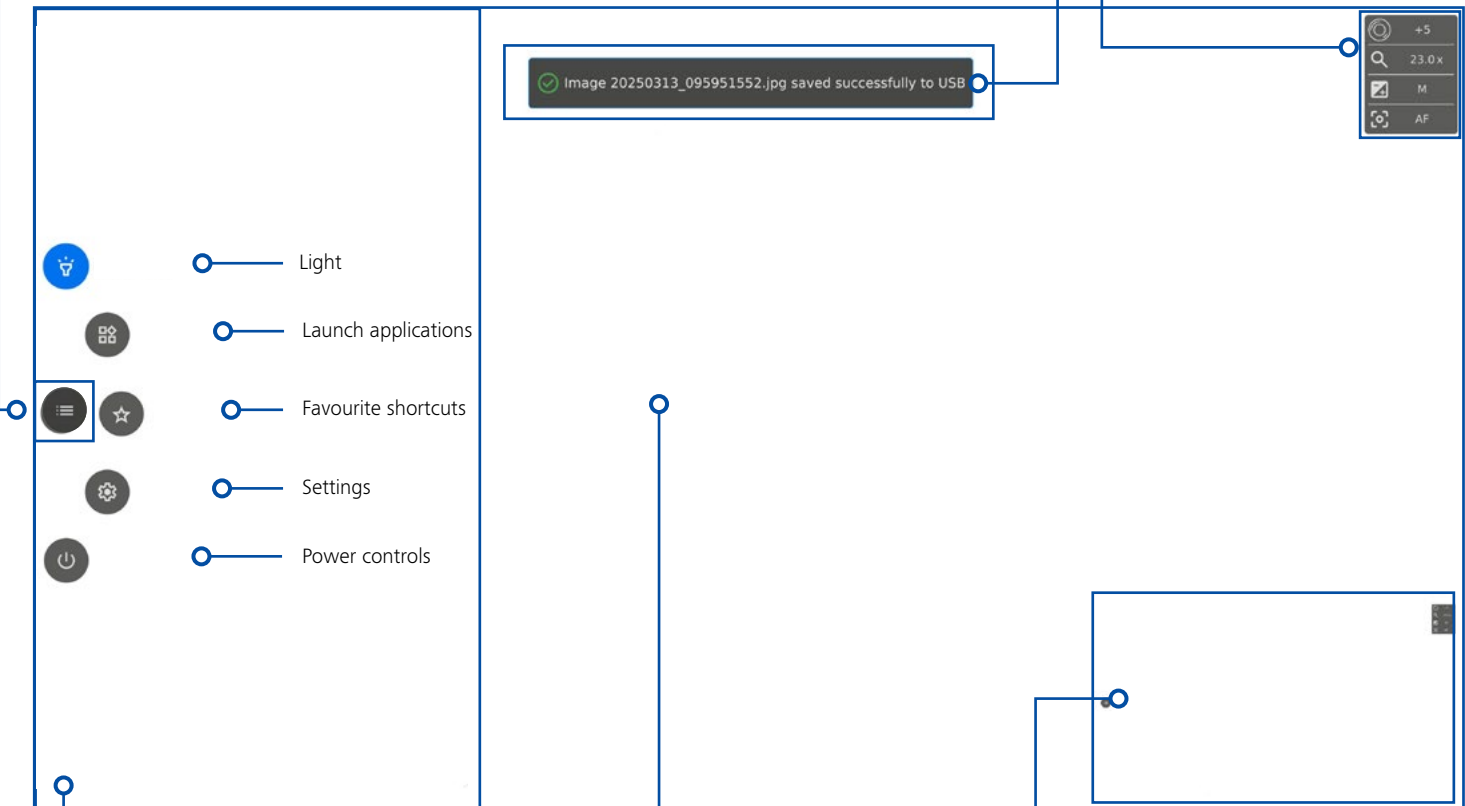

2. Control - when menu is open

Microscope menu with access to settings, features and software.

5. Live view

This is where the microscope live image is displayed.

3. Notification

Notification box displays important operational messages categorized into three levels: Info, Warning and Error.

4. Microscope settings

See the current microscope settings, always visible on top of live image.

- Objective mounted on the microscope
- Magnification level
- Exposure mode (Auto, aperture, shutter, manual)
- Focus mode (Autofocus or manual focus)

6. Preview

When capturing images, you can see a preview of your captured image.

4.2 Menu features

A variety of features will become available, when you open the menu. Let's look at them in more detail.

4.2.1 Light

Control the integrated light and Magnetic ring light (when mounted on the microscope).

The screenshot shows the microscope's control interface. On the left is a vertical sidebar with icons for light, camera, star, settings, and power. The main area displays the 'Light' menu with two sections: 'Integrated Light' and 'Ring Light'. The 'Integrated Light' section has an 'On' toggle, a 'Brightness' slider, and a 'Ring Light' section. The 'Ring Light' section has an 'On' toggle, a 'Brightness' slider, 'Elements' set to 16, and 'Rotation' set to 0°. A secondary menu on the right shows '+5', '13.1x', 'M', and 'AF'. Two callout boxes provide details: one for 'Integrated light: Intensity' and another for 'Ring light'.

Integrated light: Intensity
Turn integrated light on/off.
When the light is turned on, you can adjust its intensity and brightness.

Ring light
Control the ring light, including its intensity, number of active elements and their rotation.
Note that this section of the Light menu is only visible when the Magnetic ring light is mounted on the microscope.

4.2.2.2 Measurement app

With the Measurement app, you can perform accurate measurements after making a new calibration or recalling a previous calibration.

Before getting started

To use the Measurement app, connect a mouse and keyboard and bring out your A, B, C, D, E, F, G, H and I Dot grid calibration sheets.

Calibration sheets A, B and C are available at: <https://portal.zeiss.com/download-center/documents>

The remaining calibration sheets were provided in your delivery.





1

2

Features

Name

Description

1		Recall/delete calibrations	<p>Access your saved calibrations in the dropdown menu. Note: Only calibrations with the chosen objective will be available in the dropdown menu.</p> <p>Recall calibration Choose a saved calibration from the dropdown to recall the zoom and focus used at the time of the calibration.</p> <ul style="list-style-type: none"> ■ If the image goes out of focus after recalling a calibration, the height of the microscope might have been changed. In this case, adjust the height of the microscope until the image becomes sharp to obtain the highest precision. ■ It's also important that you use the same close up objective as during the initial calibration. ■ All measurement annotations will remain after recalling a calibration. All measurement values will also be recalculated based on the selected values. If needed, use the Edit function to readjust any measurement. <p>Delete a calibration To delete a saved calibration, click on the Recall dropdown menu and then choose the X icon next to the calibration in question. A warning dialog box prevents you from deleting a calibration unintentionally. Press "OK" to delete the calibration.</p>
2		New calibration	<p>Create a new calibration with the selected close-up objective, zoom and focus value if no saved calibrations are available with these settings.</p> <p>Calibrations can be done with three methods, all of which will be explained on the next pages:</p> <ul style="list-style-type: none"> ■ Method 1 - Dot grid: For objectives +3, +5 and +10. ■ Method 2 - Linear calibration: For objective +25. ■ Method 3 - Custom grid: For objective +25.

w

Content

1 Safety

- 1.1 Intended use
- 1.2 Warnings

2 Assembling your microscope

- 2.1 Assembly
- 2.2 Connecting
- 2.3 Power on
- 2.4 Changing objectives
- 2.5 Using the magnetic ring light

3 Control options

- 3.1 Controller
- 3.2 Keyboard
- 3.3 Foot switch
- 3.4 Mouse
- 3.5 Open API

4 Menu

- 4.1 Graphical user interface
- 4.2 Menu features
 - 4.2.1 Light
 - 4.2.2 Applications
 - 4.2.2.1 Ruler app
 - 4.2.2.2 Measurement app
 - 4.2.3 Favourite shortcuts
 - 4.2.4 Settings
 - 4.2.4.1 Settings - General
 - 4.2.4.3 Settings - Network
 - 4.2.4.3 Settings - Camera
 - 4.2.5 Power controls

5 Other features

- 5.1 File share

6 Maintenance & support

- 6.1 Taking care of your microscope
- 6.2 Warranty
- 6.3 Troubleshooting
- 6.4 Support
- 6.5 Technical specifications
- 6.6 Declaration of conformity

7 Notes



Method 1: Dot grid calibration

Advanced calibration is done automatically by placing a predefined dot grid calibration sheet under the camera and taking a picture.

While running the calibration, the software will automatically compensate for objective curve distortion and carry out calculations with a precision of sub-pixels.

1. Select a suitable magnification level.
2. Press New calibration.
3. Place the recommended calibration sheet straight under your microscope, so that the top row of dots is visible. Let the app know that the correct sheet has been placed under the microscope by selecting the recommended calibration sheet in the drop down menu under Actual calibration sheet.
4. Click Run calibration and check if the result says PASS. If the calibration sheet is placed incorrectly, the calibration will fail.
5. If the Result says FAIL, switch to Live view to adjust the position of the calibration sheet and recalibrate by pressing Run calibration again.
6. When the calibration is complete, click OK to save the new calibration and close calibration state.
7. Click Cancel to close without saving the calibration.

After a passed calibration, the Precision, Field of view (FOV), Lens and Magnification of the calibration are stated in the Calibration information window.

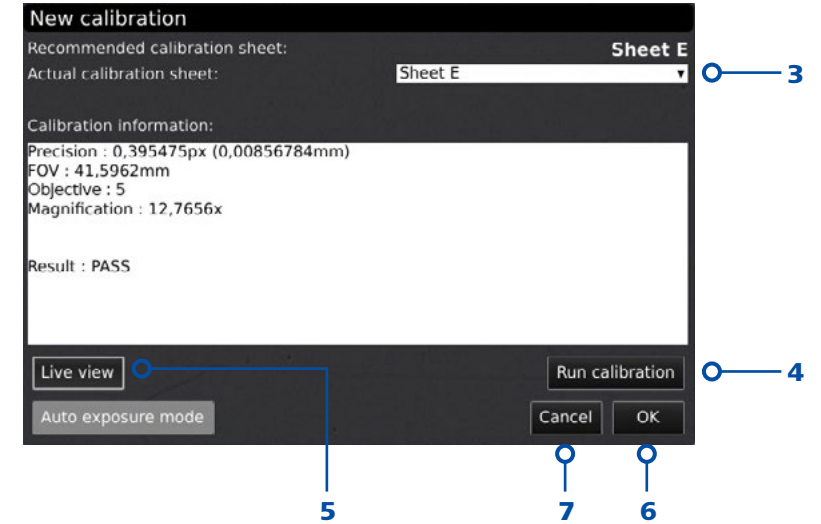

What calibration card should you use?

Sheet	Range [mm]	Range [inches]
	min - max	min - max
A	204 - 340	8.03 - 13.39
B	123 - 204	4.84 - 8.03
C	74 - 123	2.91 - 4.84
D	44 - 74	1.73 - 2.91
E	26 - 44	1.02 - 1.73
F	16 - 26	0.63 - 1.02
G	10 - 16	0.39 - 0.63
H	6 - 10	0.24 - 0.39
I	3 - 6	0.12 - 0.24

Method 2: Linear calibration

This is a calibration method where you use a reference line and state the line length. The measurement accuracy depends on the user's diligence when drawing the reference line. Linear calibration does not compensate for objective curve distortion.

1. Select a suitable magnification level.
2. Press New calibration.
3. Select Linear calibration in the drop down menu under Actual calibration sheet.
4. Find an object with measurable distances (e.g. a ruler) and place it under the microscope. Provide the distance you want to measure and matching unit. If needed, zoom in and adjust the end points of the reference line for increased precision. When measuring on a ruler, always measure from forefront to forefront of the lines on the ruler.
5. Click Run calibration and check if the result says PASS. If the markers are placed incorrectly, the calibration will fail.
6. If the Result says FAIL, switch to Live view to zoom in and adjust the position of the markers and recalibrate by pressing Run calibration again.
7. When the calibration is complete, click OK to save the new calibration and close calibration state.
8. Click Cancel to close without saving the calibration.

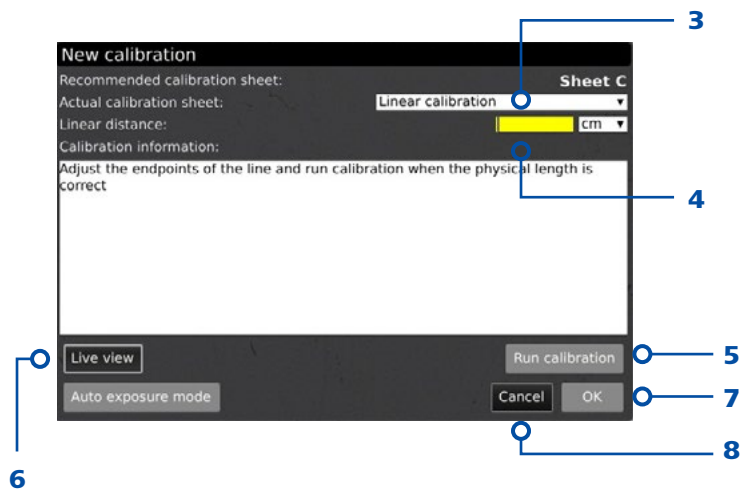

Method 3: Custom grid

Advanced calibration is done automatically by placing any predefined dot grid calibration tool under the camera and taking a picture. While running the calibration, the software will automatically compensate for objective curve distortion.

The dots should at least have a diameter of 20 px on the screen to be recognized by the calibration mechanism.

1. Select a suitable magnification level.
2. Press New calibration.
3. Select Custom dotgrid in the drop down menu under Actual calibration sheet.
4. Provide the dot spacing measure and matching unit. Place the calibration grid straight under the microscope, so that the top row of dots is visible.
5. Click Run Calibration and check if the Result says PASS. If the calibration sheet is placed incorrectly, the calibration will fail.
6. If the Result says FAIL, switch to Live view to zoom in and adjust the position of the markers to adjust the position of the calibration sheet and recalibrate by pressing Run calibration again.
7. When the calibration is complete, click OK to save the new calibration and close calibration state.
8. Click Cancel to close without saving the calibration.

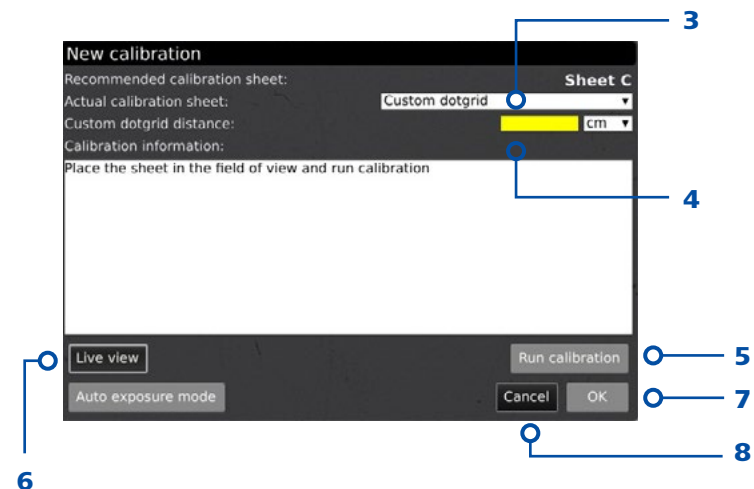

Content

1 Safety

- 1.1 Intended use
- 1.2 Warnings

2 Assembling your microscope

- 2.1 Assembly
- 2.2 Connecting
- 2.3 Power on
- 2.4 Changing objectives
- 2.5 Using the magnetic ring light

3 Control options

- 3.1 Controller
- 3.2 Keyboard
- 3.3 Foot switch
- 3.4 Mouse
- 3.5 Open API

4 Menu

- 4.1 Graphical user interface
- 4.2 Menu features
 - 4.2.1 Light
 - 4.2.2 Applications
 - 4.2.2.1 Ruler app
 - 4.2.2.2 Measurement app
 - 4.2.3 Favourite shortcuts
 - 4.2.4 Settings
 - 4.2.4.1 Settings - General
 - 4.2.4.3 Settings - Network
 - 4.2.4.3 Settings - Camera
 - 4.2.5 Power controls

5 Other features







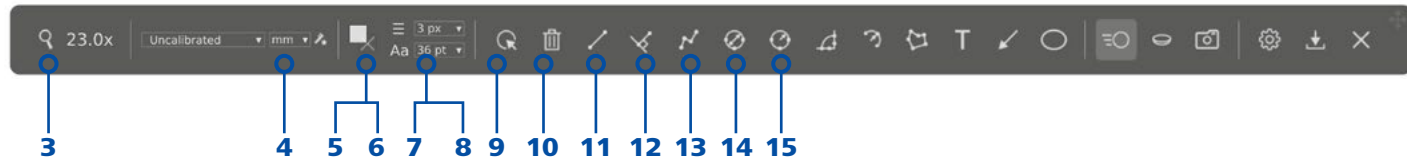

- 5.1 File share

6 Maintenance & support

- 6.1 Taking care of your microscope
- 6.2 Warranty
- 6.3 Troubleshooting
- 6.4 Support
- 6.5 Technical specifications
- 6.6 Declaration of conformity

7 Notes







Features	Name (shortcut)	Description
3 	Magnification level	Use the keyboard to change magnification level. Press the magnification field to state an exact magnification level.
4 	Measurement units	Choose your preferred measurement units in the dropdown menu. It is possible to choose between mm, cm and inches.
5 	Object and text color adjustment	Set the colors for drawings and texts before using a tool. You are not able to edit the color after using the tool. Latest settings are persistent during power down. The color is set to black by default.
6 	Background color adjustment	Adjust the color of the text annotation background before using the text annotation tool. You are not able to edit the color after starting using the tool. Latest settings are persistent during power down. The color is set to transparent by default.
7 	Line width	Choose the line width of your measurement lines in pixels (px). Latest settings are persistent during power down. The width is set to 1 px by default.
8 	Text size	State the text size of your measurement units and text annotations in points (pt). Latest settings are persistent during power down. The size is set to 14 pt by default.
9 	Edit (F1)	In edit mode, all adjustable points will be shown as small circles that are highlighted (red circles) on mouse over. When a point is highlighted, you can choose and relocate the point. In view mode, the points are hidden. By right-clicking on a point, you are able to delete the point.
10 	Clear all (F2)	Use this button to clear all drawings. When Clear All is selected, a warning dialog enables you to cancel the operation if it was selected by accident.

Function shortcuts and tool tips

Function key shortcuts (F1-F12) have been assigned to the drawing and annotation functions. The tool tip shows the assigned function key. See assigned shortcuts at each function below.

Note: When you mouseover a menu point, a text box will show tool tips.

11		Point-to-point measurement (F3)	<p>Measure the distance between two points. Use left mouse click to place the two end points.</p> <ul style="list-style-type: none">■ Hold down Shift when placing the end point: Create horizontal or vertical line.■ Hold down Ctrl while placing the start and end point: Line will snap to the center of a measured circle or arc. This can be used to easily measure the distance between the center of two measured circles or arcs.■ Press Ctrl when placing the lines: Extend the base lines. This can be used for measuring the distance between parallel objects. When the line has been placed, the base lines return to their default length.■ Press Alt key while placing the last point of the measurement: Offset the measurement line annotation with dash lines. This is useful if the annotation is difficult to read when placed at default.
12		Distance to line measurement (Shift + F3)	<p>Measure the perpendicular distance between a line and a point.</p> <ul style="list-style-type: none">■ Press Ctrl when placing the lines: Extend the base lines.■ Hold Ctrl when placing the perpendicular line: Make multiple perpendicular measurements from the base line.
13		Polyline measurement (F4)	<p>Place two or more points to get the length of each distance plus the length of the full polyline.</p> <ul style="list-style-type: none">■ Hold down Shift when placing the end point: Create horizontal or vertical line.■ Hold down Ctrl while placing the start and end point: Line will snap to the center of a measured circle or arc. This can be used to easily measure the distance between the center of two measured circles or arcs.
14		Diameter measurement (F5)	<p>Calculate the diameter of a circle by placing three points in the periphery of a circle. Use left mouse click to place the three points</p>
15		Radius measurement (F6)	<p>Calculate the radius of a circle by placing three points in the periphery of a circle. Use left mouse click to place the three points</p>

Content

1 Safety

- 1.1 Intended use
- 1.2 Warnings

2 Assembling your microscope

- 2.1 Assembly
- 2.2 Connecting
- 2.3 Power on
- 2.4 Changing objectives
- 2.5 Using the magnetic ring light

3 Control options

- 3.1 Controller
- 3.2 Keyboard
- 3.3 Foot switch
- 3.4 Mouse
- 3.5 Open API

4 Menu

- 4.1 Graphical user interface
- 4.2 Menu features
 - 4.2.1 Light
 - 4.2.2 Applications
 - 4.2.2.1 Ruler app
 - 4.2.2.2 Measurement app
 - 4.2.3 Favourite shortcuts
 - 4.2.4 Settings
 - 4.2.4.1 Settings - General
 - 4.2.4.3 Settings - Network
 - 4.2.4.3 Settings - Camera
 - 4.2.5 Power controls

5 Other features







- 5.1 File share

6 Maintenance & support

- 6.1 Taking care of your microscope
- 6.2 Warranty
- 6.3 Troubleshooting
- 6.4 Support
- 6.5 Technical specifications
- 6.6 Declaration of conformity

7 Notes



Features	Name (shortcut)	Description
16 	Angle measurement (F7)	Measure any given angle. Use left mouse click to place four points - two on each side of the angle you want to measure.
17 	Arc measurement (Shift + F7)	Use this tool to measure the radius, angle and total length of an arc. Place three markers to define the arc using the left mouse button. Abort the process and delete the arc by right-clicking the mouse at any point. <ul style="list-style-type: none">■ Radius = Measured from arc center point to arc line■ Angle = Measured from arc center point, using start and end points as markers■ Total length = The total length of the arc line
18 	Area measurement (F8)	Make a polygon area measurement by using left mouse clicks to place at least three points. To stop adding points to your polygon right-click on the mouse.
19 	Text Annotation (F9)	Add text annotations anywhere in the window. Use the Keyboard to type the text. Move the text box to the wanted location and left click the mouse to confirm the position. <p>The feature includes auto completion allowing you to easily select or delete previously entered text annotations.</p>
20 	Arrow Annotation (F10)	Add arrow annotations anywhere in the window. Use the left mouse button to place the endpoints. The second point is the end of the arrow.
21 	Ellipse/Circle Annotation (F11)	Add ellipse annotations anywhere in the window. Use the left mouse button to place the start and end points of the ellipse. <ul style="list-style-type: none">■ Hold Shift when placing the end point: Create a perfect circle.

22		Live View (F12)	<p>Toggle between live and still image mode.</p> <ul style="list-style-type: none"> ■ In Live mode, the live camera image is active. ■ In Still image mode, the latest snapshot will be shown. ■ Ctrl + L (x 2): Replace the latest captured snapshot. Use shortcut again to toggle back to Live view.
23		Objective Correction (Shift + F12)	<p>Correct image for objective curve distortion when in a calibrated state, not in lineary calibrated mode.</p> <p>Feature can also be used to toggle between latest snapshot and a corrected version of the snapshot.</p>
24		Snapshot (Ctrl + F12)	<p>Take a snapshot of the live image. The snapshot will not be saved automatically.</p> <p>NB: When using the mouse wheel to zoom digitally on a snapshot, the center of the zoom follows the mouse position.</p>
25		Settings (Ctrl + O)	<p>Once clicking this icon, a pop-up window with additional settings will appear.</p> <ul style="list-style-type: none"> ■ Mouse : Adjust the mouse sensitivity by selecting a point on the bar between slow and fast. ■ Decimals: Choose the number of decimals you want your measurements to be displayed with by using the drop down menu. ■ Text: Choose how line length annotations should be displayed: Select All text horizontal to have the text displayed horizontally on the monitor. When unselected (default), the text will be parallel to the line. All previous length annotations will change to the selected setting. ■ Also select or deselect Show arc length, angle and/or radiusto show or hide these arc measurements.

Content

1 Safety

- 1.1 Intended use
- 1.2 Warnings

2 Assembling your microscope

- 2.1 Assembly
- 2.2 Connecting
- 2.3 Power on
- 2.4 Changing objectives
- 2.5 Using the magnetic ring light

3 Control options

- 3.1 Controller
- 3.2 Keyboard
- 3.3 Foot switch
- 3.4 Mouse
- 3.5 Open API

4 Menu

- 4.1 Graphical user interface
- 4.2 Menu features
 - 4.2.1 Light
 - 4.2.2 Applications
 - 4.2.2.1 Ruler app
 - 4.2.2.2 Measurement app
 - 4.2.3 Favourite shortcuts
 - 4.2.4 Settings
 - 4.2.4.1 Settings - General
 - 4.2.4.3 Settings - Network
 - 4.2.4.3 Settings - Camera
 - 4.2.5 Power controls

5 Other features

- 5.1 File share

6 Maintenance & support

- 6.1 Taking care of your microscope
- 6.2 Warranty
- 6.3 Troubleshooting
- 6.4 Support
- 6.5 Technical specifications
- 6.6 Declaration of conformity

7 Notes



Features

Name (shortcut)

Description

26



File menu (Ctrl + D)

Once clicking this icon, a pop-up window with additional settings related to saving images and measurements will appear.

Save image:

Images can be saved with or without graphic (any measurements or annotations added to the image):

- Ctrl + S: Save image with graphics.
- Ctrl + W: Save image without graphics.
- Ctrl + Shift + S: Save a full screendump.

When taking a picture, an information window will appear for a few seconds, showing the file name and storage location.

Save measurements

To reuse measurements for future inspections, measurements can be saved with or without the microscope image included in the file

Load measurements

Previously saved measurements can be loaded from a dropdown menu during future inspections.

Any additional measurements or alterations to existing measurements will not be saved automatically. In this case, make sure to save the measurements again.

NB: To delete saved measurements, click the cross icon next to the measurement in the Load measurement menu tab.

27



Close (Ctrl + Q)

Use this function or hold center button down for a few seconds to close the app.

28



Move Toolbar

Press and hold left mouse button down to move the toolbar around the window and place it by releasing the mouse button.

4.2.3 Favourite shortcuts

Access your presets quickly in the Favorites menu.

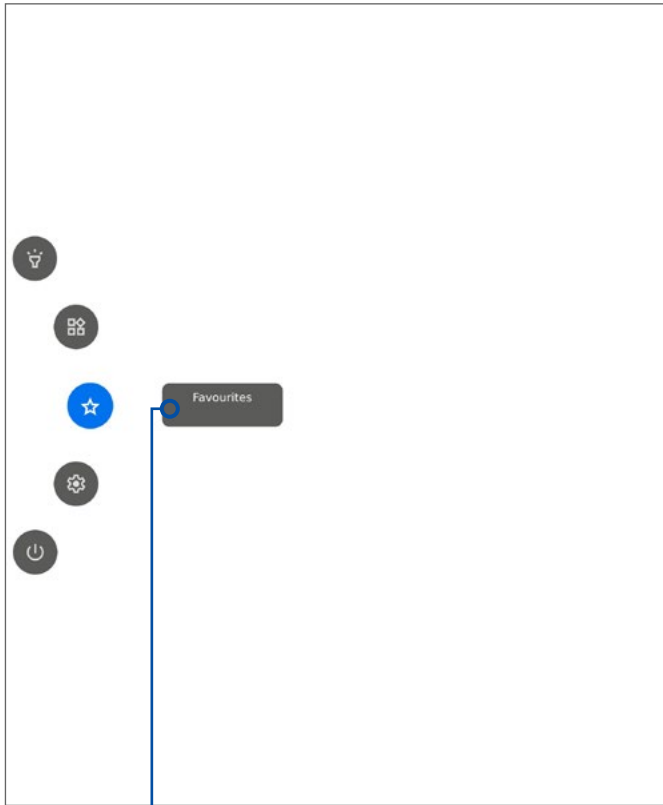

Quick access to selected features and presets

(Currently not available)

4.2.4 Settings

Access and adjust the microscope's general settings, presets as well as network and camera settings.

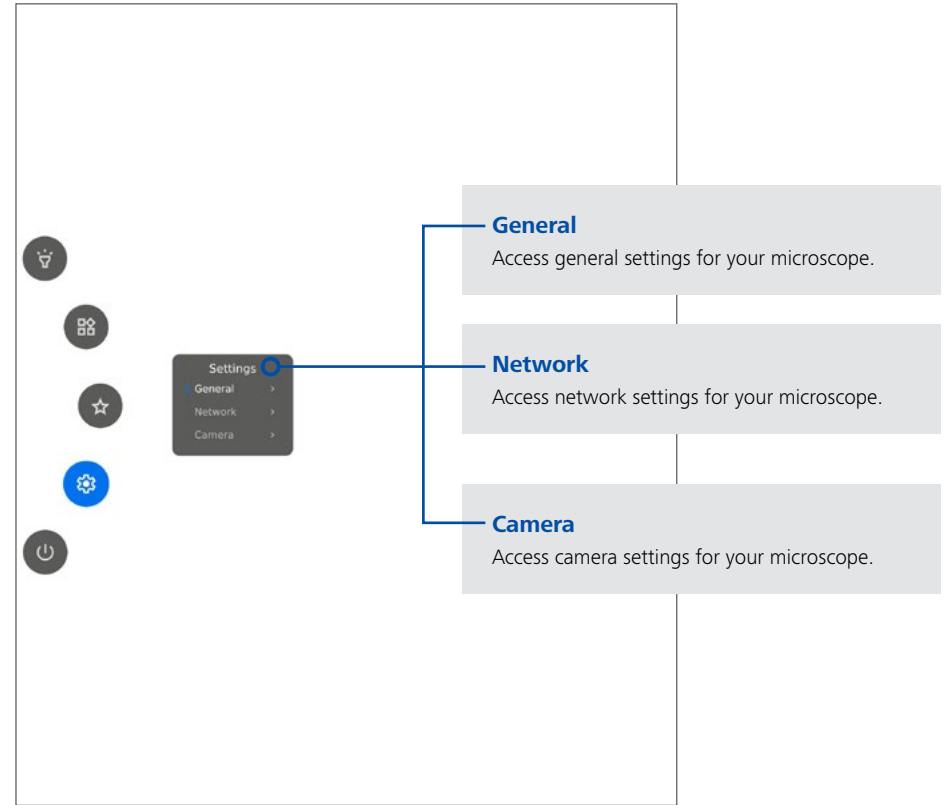

General

Access general settings for your microscope.

Network

Access network settings for your microscope.

Camera

Access camera settings for your microscope.

Content

1 Safety

1.1 Intended use

1.2 Warnings

2 Assembling your microscope

2.1 Assembly

2.2 Connecting

2.3 Power on

2.4 Changing objectives

2.5 Using the magnetic ring light

3 Control options

3.1 Controller

3.2 Keyboard

3.3 Foot switch

3.4 Mouse

3.5 Open API

4 Menu

4.1 Graphical user interface

4.2 Menu features

4.2.1 Light

4.2.2 Applications

4.2.2.1 Ruler app

4.2.2.2 Measurement app

4.2.3 Favourite shortcuts

4.2.4 Settings

4.2.4.1 Settings - General

4.2.4.3 Settings - Network

4.2.4.3 Settings - Camera

4.2.5 Power controls

5 Other features

5.1 File share

6 Maintenance & support

6.1 Taking care of your microscope

6.2 Warranty

6.3 Troubleshooting

6.4 Support

6.5 Technical specifications

6.6 Declaration of conformity

7 Notes

4.2.4.1 Settings - General

A wide range of settings will become available when selecting General under Settings.

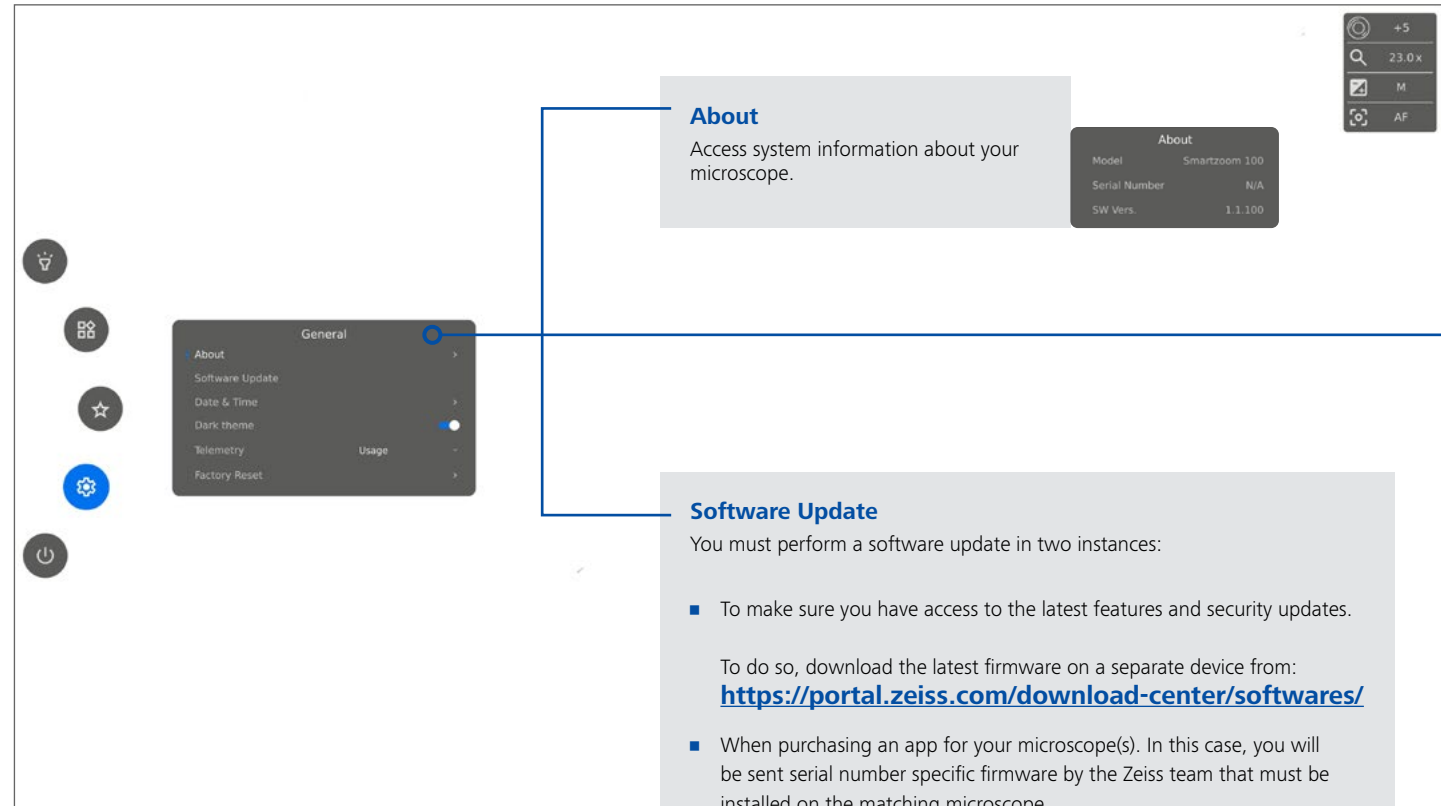

About

Access system information about your microscope.

About	
Model	Smartzoom 100
Serial Number	N/A
SW Vers.	1.1.100

Software Update

You must perform a software update in two instances:

- To make sure you have access to the latest features and security updates.

To do so, download the latest firmware on a separate device from:

<https://portal.zeiss.com/download-center/software/>

- When purchasing an app for your microscope(s). In this case, you will be sent serial number specific firmware by the Zeiss team that must be installed on the matching microscope.

To install the firmware:

- Transfer the downloaded/forwarded firmware/ZIP file to an empty USB storage device
- Insert the USB storage device in the back of the Controller
- Go to System update in the microscope menu

Date & Time

Change time and date of your microscope for accurate naming of captured photos.

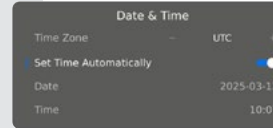

Dark Theme

Switch between Dark and Light theme.



Telemetry

Change which operational data you want ZEISS to have permission to collect. This data will be used to optimize features and develop future enhancements tailored to your needs.

- **Debug:** Allows ZEISS to collect detailed diagnostic information intended for troubleshooting and support cases. No sensitive or identifiable data is gathered.
- **Error:** Allows ZEISS to collect non-identifiable technical data to identify and address issues that could impact the microscope's performance and reliability.
- **Usage:** Allows ZEISS to collect general usage data reflecting operational patterns. No intellectual property or identifiable information is collected.

As default, Usage is selected.



Factory Reset

Restore microscope settings to the state it was originally in.

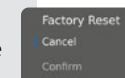

Content

1 Safety

1.1 Intended use

1.2 Warnings

2 Assembling your microscope

2.1 Assembly

2.2 Connecting

2.3 Power on

2.4 Changing objectives

2.5 Using the magnetic ring light

3 Control options

3.1 Controller

3.2 Keyboard

3.3 Foot switch

3.4 Mouse

3.5 Open API

4 Menu

4.1 Graphical user interface

4.2 Menu features

4.2.1 Light

4.2.2 Applications

4.2.2.1 Ruler app

4.2.2.2 Measurement app

4.2.3 Favourite shortcuts

4.2.4 Settings

4.2.4.1 Settings - General

4.2.4.3 Settings - Network

4.2.4.3 Settings - Camera

4.2.5 Power controls

5 Other features

5.1 File share

6 Maintenance & support

6.1 Taking care of your microscope

6.2 Warranty

6.3 Troubleshooting

6.4 Support

6.5 Technical specifications

6.6 Declaration of conformity

7 Notes

4.2.4.3 Settings - Network

When selecting Network under Settings, you can see your IP and MAC address and control your access to the microscope API.

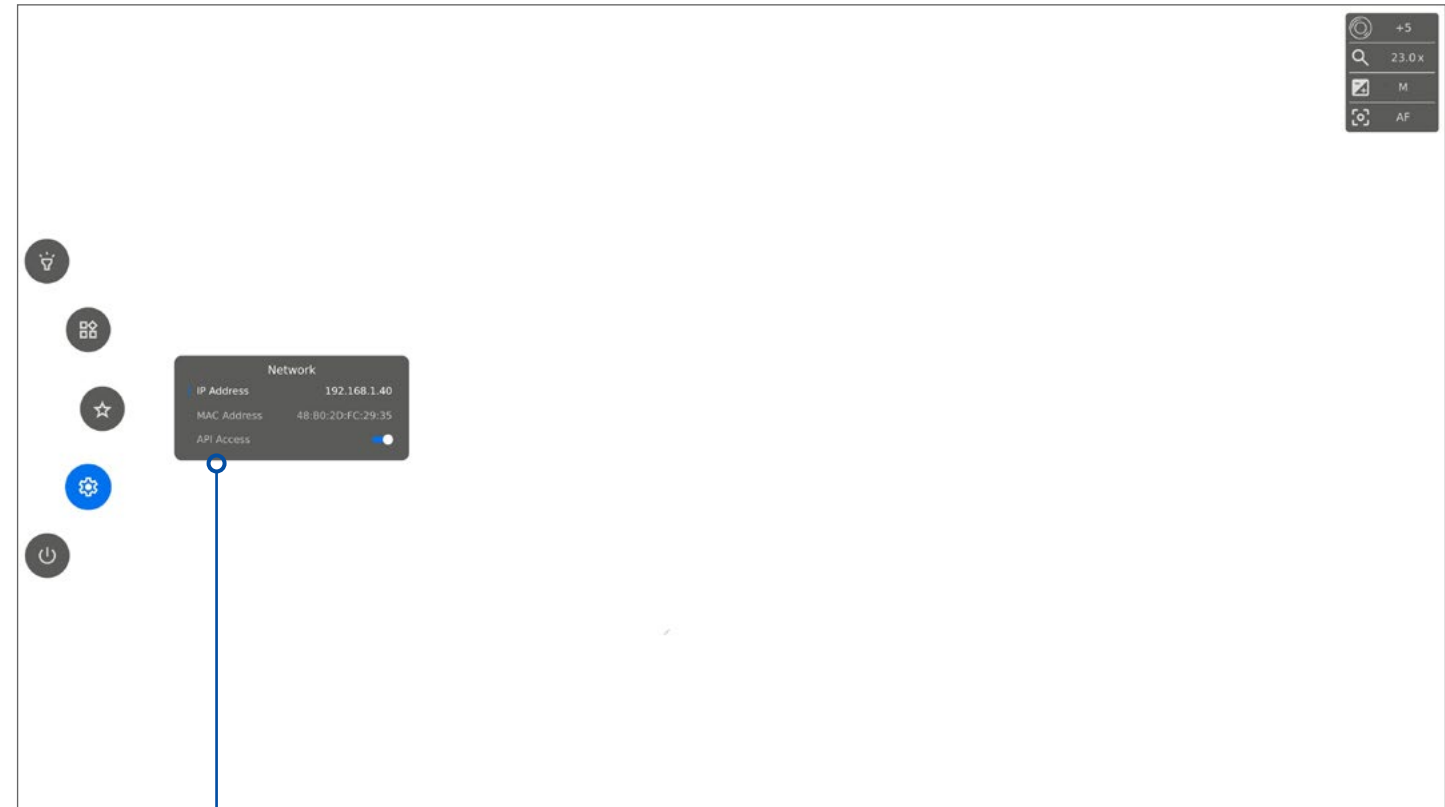

IP Address

See your IP address if the microscope is connected to the internet.

The IP address is obtained automatically via DHCP.

MAC Address

See your MAC address if the microscope is connected to the internet.

API Access

Activate/Deactivate access to microscope API on local area network (Requires valid subscription license).

4.2.4.3 Settings - Camera

In the Camera section, you can control various camera settings.

Autofocus
Turn Autofocus on/off. When turned off, you can control the focus manually.

Exposure
Change Exposure mode according to your object and microscope location.

- **Auto:** Exposure compensation can be manually adjusted. Aperture, Shutter speed and Gain are automatically adjusted.
- **Manual:** Aperture, Shutter speed and Gain can be manually adjusted.
- **Shutter Priority:** Shutter speed and Exposure Compensation can be manually adjusted. Aperture and Gain are automatically adjusted.
- **Aperture Priority:** Aperture and Exposure Compensation can be manually adjusted. Shutter Speed and Gain are automatically adjusted.

As default, Auto mode is selected.

Camera Settings:
Autofocus: [On]
Exposure Mode: Manual
Aperture: F1.6
Shutter Speed: 1/60 s
Gain: 25.0 dB
Exposure Comp.: Off
White Balance Mode: Manual
Auto Calibrate w/light: [On]
Objective: +5
Auto Height Adjustment: [On]

Top Bar:
+5
23.0 x
M
AF

Find information on the White balance and Objective section on the next page.

- Aperture**
Change the amount of light entering the camera, to affect depth of field and image brightness.
- Shutter Speed**
Change the duration for which the camera sensor is exposed to light, to affect sharpness and light sensitivity.
- Gain**
Change the amplification of the image signal, to affect brightness in low-light conditions.
- Exposure Compensation**
Change the overall exposure, to make image brighter or darker (without affecting aperture and shutter speed).

Content

1 Safety

- 1.1 Intended use
- 1.2 Warnings

2 Assembling your microscope

- 2.1 Assembly
- 2.2 Connecting
- 2.3 Power on
- 2.4 Changing objectives
- 2.5 Using the magnetic ring light

3 Control options

- 3.1 Controller
- 3.2 Keyboard
- 3.3 Foot switch
- 3.4 Mouse
- 3.5 Open API

4 Menu

- 4.1 Graphical user interface
- 4.2 Menu features
 - 4.2.1 Light
 - 4.2.2 Applications
 - 4.2.2.1 Ruler app
 - 4.2.2.2 Measurement app
 - 4.2.3 Favourite shortcuts
 - 4.2.4 Settings
 - 4.2.4.1 Settings - General
 - 4.2.4.3 Settings - Network
 - 4.2.4.3 Settings - Camera
 - 4.2.5 Power controls

5 Other features

- 5.1 File share

6 Maintenance & support

- 6.1 Taking care of your microscope
- 6.2 Warranty
- 6.3 Troubleshooting
- 6.4 Support
- 6.5 Technical specifications
- 6.6 Declaration of conformity

7 Notes

The image shows a screenshot of the microscope's camera settings menu. The menu is titled 'Camera' and has 'Autofocus' turned on. The 'Exposure' section includes Mode (Manual), Aperture (F1.6), Shutter Speed (1/60 s), Gain (25.0 dB), and Exposure Comp. (Off). The 'White Balance' section includes Mode (Manual), Calibrate, and Auto Calibrate w/light (On). The 'Objective' is set to +5, and 'Auto Height Adjustment' is turned on. Callouts point to the White Balance section, the Objective setting, the Auto Height Adjustment setting, the Calibrate button, and the Auto Calibrate w/light setting. A separate callout points to the 'Calibrate' button with instructions on how to perform a White Balance Calibration (WBC).

White Balance

Change how often the microscope will perform a White balance calibration (WBC).

WBCs ensure accurate color display.

- **Auto:** The microscope will constantly adjust the color temperature of the image to the surrounds to ensure accurate color display.
- **Manual:** Allows you to fine-tune the color balance of the microscope's camera to ensure accurate and natural color reproduction under different lighting conditions. WB can only be modified by calibration.
- **Indoor:** Fixed settings according to color temperature matching general indoor lighting.

As default, the microscope is in Manual mode.

When changing to Manual, two additional settings will become available.

Objective

For accurate magnification level displayed in the Information window, specify the objective currently mounted on the microscope after changing objectives.

When doing so, it's recommended that you use the Automatic Height Adjustment feature under General settings to obtain the right free working distance.

Auto Height Adjustment

By activating the Auto Height Adjustment feature, the microscope will adjust itself to the correct free working distance, giving you the sharpest image possible. When the adjustment is complete, the feature will deactivate itself until it is reactivated.

It's recommended that you use the Auto Height Adjustment feature when changing objectives or introducing/removing elevated surfaces underneath your objects.

Calibrate

Perform WBC now by placing a Gray card in the microscope's field of view. Alternatively, you can use a white piece of paper.

Auto Calibrate w/light

Enable auto calibrations when integrated light or ring light (if connected) is turned on/off.

4.2.5 Power controls

Access various power control options.

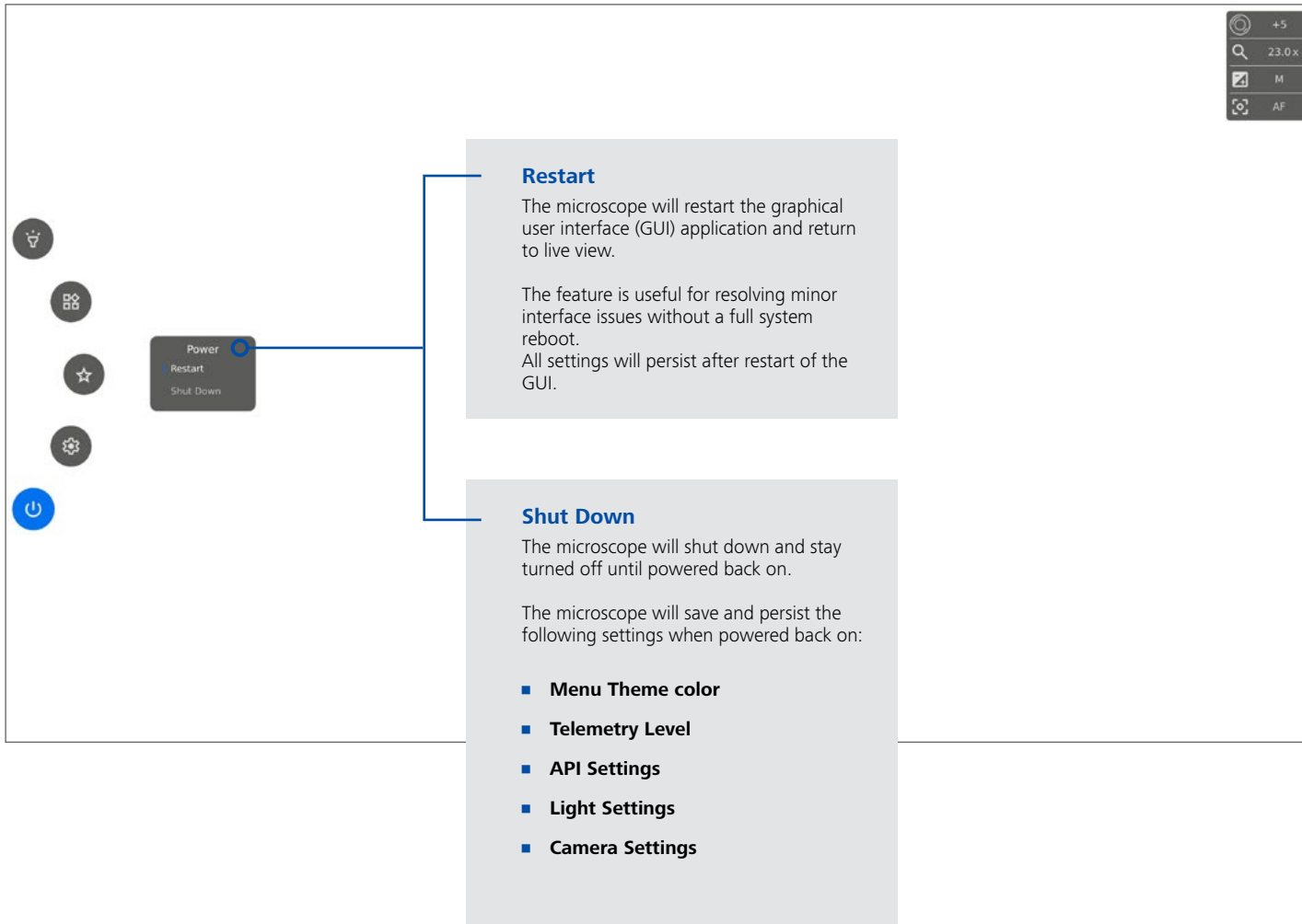

The image shows a screenshot of a microscope's graphical user interface (GUI). On the left side, there is a vertical stack of five circular icons: a lightbulb, a camera, a star, a gear, and a power button. A 'Power' menu is open, showing 'Restart' and 'Shut Down' options. Two callout boxes provide details for these options. The 'Restart' box explains that it restarts the GUI application and returns to live view, useful for resolving minor interface issues without a full system reboot, and that all settings will persist. The 'Shut Down' box explains that the microscope will shut down and stay off until powered back on, and that it will save and persist the following settings: Menu Theme color, Telemetry Level, API Settings, Light Settings, and Camera Settings. In the top right corner, there is a control panel with icons for zoom (+5), magnification (23.0x), a menu icon (M), and autofocus (AF).

Restart

The microscope will restart the graphical user interface (GUI) application and return to live view.

The feature is useful for resolving minor interface issues without a full system reboot. All settings will persist after restart of the GUI.

Shut Down

The microscope will shut down and stay turned off until powered back on.

The microscope will save and persist the following settings when powered back on:

- **Menu Theme color**
- **Telemetry Level**
- **API Settings**
- **Light Settings**
- **Camera Settings**

Content

1 Safety

1.1 Intended use

1.2 Warnings

2 Assembling your microscope

2.1 Assembly

2.2 Connecting

2.3 Power on

2.4 Changing objectives

2.5 Using the magnetic ring light

3 Control options

3.1 Controller

3.2 Keyboard

3.3 Foot switch

3.4 Mouse

3.5 Open API

4 Menu

4.1 Graphical user interface

4.2 Menu features

4.2.1 Light

4.2.2 Applications

4.2.2.1 Ruler app

4.2.2.2 Measurement app

4.2.3 Favourite shortcuts

4.2.4 Settings

4.2.4.1 Settings - General

4.2.4.3 Settings - Network

4.2.4.3 Settings - Camera

4.2.5 Power controls

5 Other features

5.1 File share

6 Maintenance & support

6.1 Taking care of your microscope

6.2 Warranty

6.3 Troubleshooting

6.4 Support

6.5 Technical specifications

6.6 Declaration of conformity

7 Notes

5 Other features

In this section, you'll learn how to use the microscope's full potential, including features that are not linked to a specific menu feature.

5.1 File share

To save photos of your work on the microscope, connect a USB storage device either to the back of the Controller or the back of the microscope.

To access your saved photos, unplug the USB storage device and connect it to your computer. You can now access your photos on the computer and transfer them to a destination of your choice.

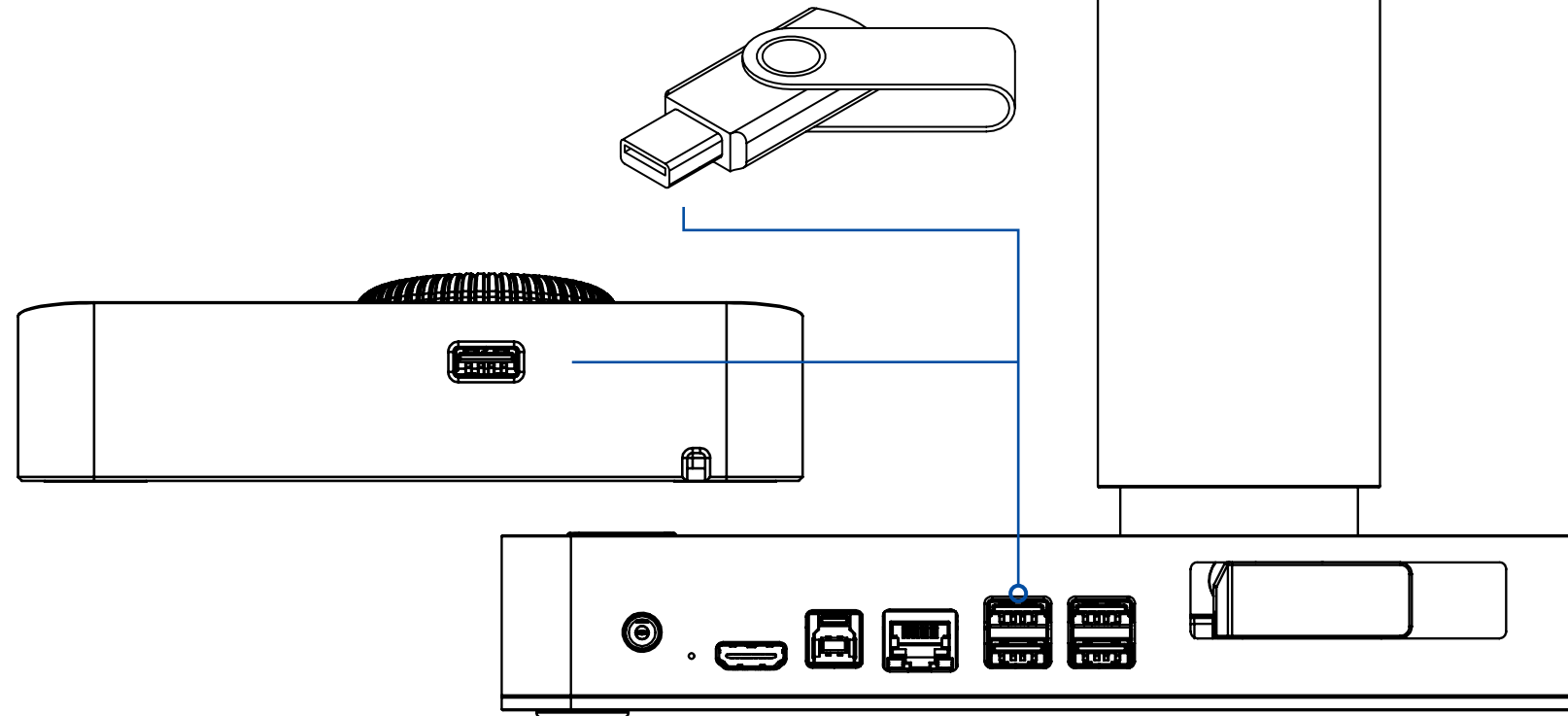

In this section, you'll learn how to handle and do maintenance on your Smartzoom 100 to extend its lifespan. You'll also learn ZEISS' warranty terms and how to create a support ticket either through your local distributor or directly with ZEISS.

6 Maintenance & support

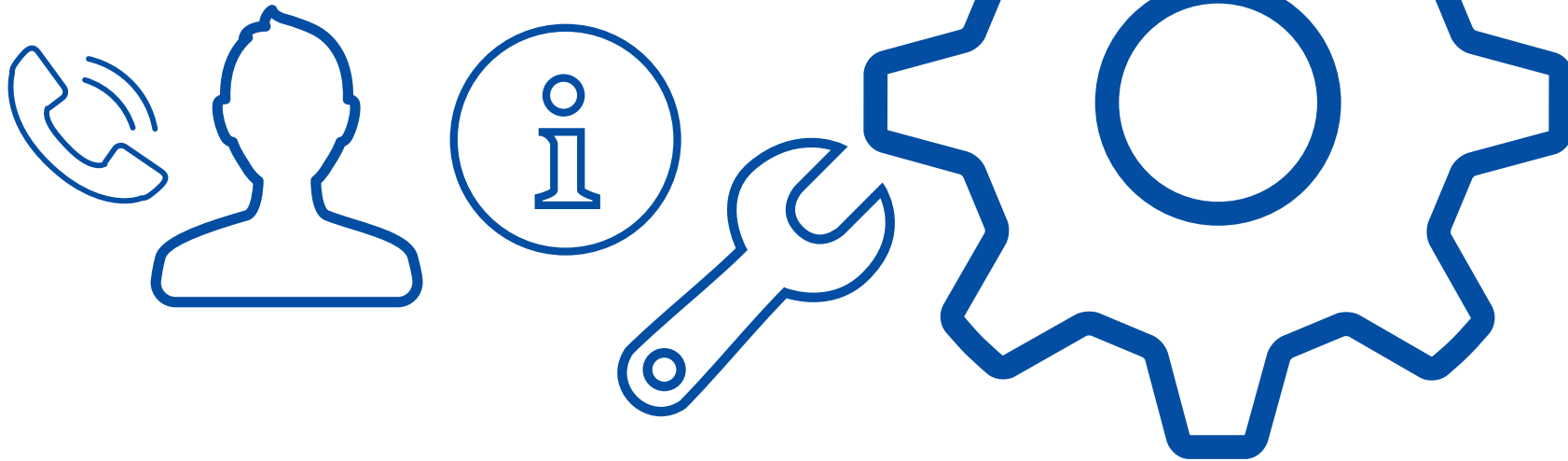

6.1 Taking care of your microscope

- Store and use the product in a dry, clean and ventilated room.
- Do not place the product in direct sunlight, next to a radiator/heater or some place where the system may be subjected to liquids.
- All plugs are designed to be used in one way only. Therefore, you should never use force when you connect the system.
- Remember to disconnect all elements if you intend to move the product.
- If you move the product from a cold to a hot room, you must wait at least an hour before you turn it on to avoid short circuits due to condensation.
- Remove the cables by pulling the plug itself - never by pulling the cable.
- If the product needs repairing, never do it yourself, contact your distributor.
- When cleaning the product, please turn off the system and wait until the system has cooled off.
- Clean the product with a damp cloth. Never use strong cleaning agents or chemicals - these may damage the microscope.
- Clean the objective regularly with isopropyl alcohol and a microfiber cloth or with the ZEISS cleaning kit.
- Please be careful when carrying the product from one place to another. Always lift the assembled microscope by placing one hand around the camera arm and the other hand beneath the base.

Content

1 Safety

1.1 Intended use

1.2 Warnings

2 Assembling your microscope

2.1 Assembly

2.2 Connecting

2.3 Power on

2.4 Changing objectives

2.5 Using the magnetic ring light

3 Control options

3.1 Controller

3.2 Keyboard

3.3 Foot switch

3.4 Mouse

3.5 Open API

4 Menu

4.1 Graphical user interface

4.2 Menu features

4.2.1 Light

4.2.2 Applications

4.2.2.1 Ruler app

4.2.2.2 Measurement app

4.2.3 Favourite shortcuts

4.2.4 Settings

4.2.4.1 Settings - General

4.2.4.3 Settings - Network

4.2.4.3 Settings - Camera

4.2.5 Power controls

5 Other features

5.1 File share

6 Maintenance & support

6.1 Taking care of your microscope

6.2 Warranty

6.3 Troubleshooting

6.4 Support

6.5 Technical specifications

6.6 Declaration of conformity

7 Notes

6.2 Warranty

Warranty terms for the product shall be as follows:

ZEISS warrants that the product will correspond with the specification at the time of delivery and will be free from defects in material and workmanship for a period of 12 months from delivery or as determined by the product invoice.

Any unauthorized intervention or use other than within the scope of the intended use shall void all rights to warranty claims. Only original spare parts may be used.

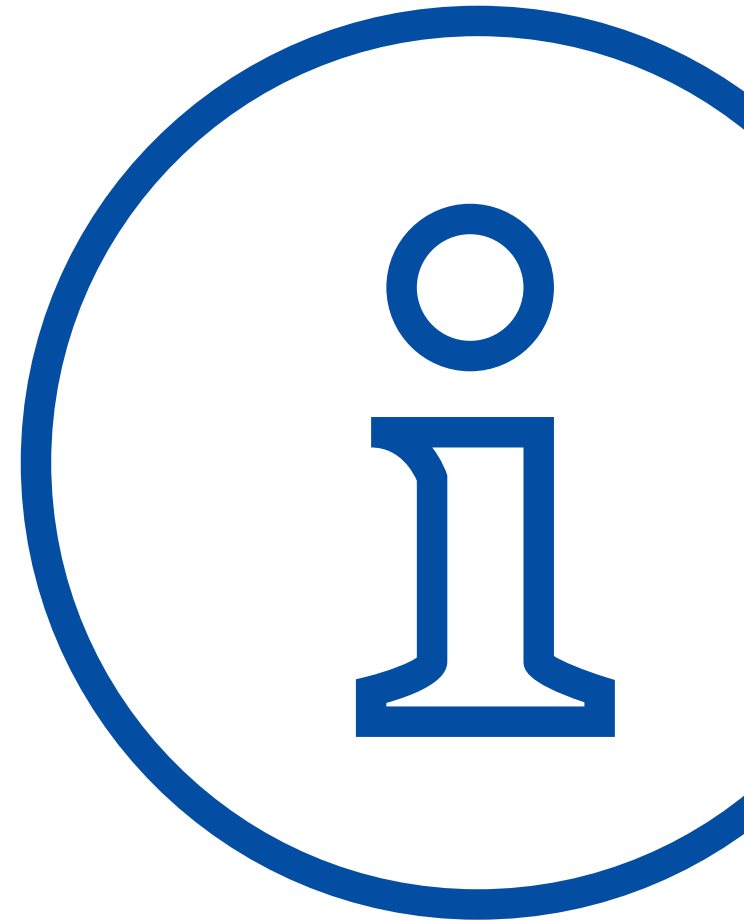

6.3 Troubleshooting

Below you can find a list of issues that you might experience with your microscope and how to solve them.

Issue	Cause	Step 1	Step 2
1	No power / Device does not turn on.	Power cable is not connected or is loose.	Check that the power cable is firmly connected to the base and plugged into a working power outlet.
2	Blurry image.	Objective is dirty or object is out of focus.	Clean the objective. Adjust the working height either manually or automatically. Then, adjust focus either manually or automatically.
3	Image display issues on monitor.	Connection issue between microscope and monitor or unsupported monitor.	Check HDMI cable for damages or loose connection. Check that monitor is 27 inch with UHD resolution on HDMI.
4	Image is colored oddly.	Light conditions have changed since last white balance calibration or white balance calibration was performed on colored surface.	Ensure white/light grey surface under microscope before performing a white balance calibration. Check HDMI cable and connection between base and monitor.
5	Ruler disappear when I change focus.	Ruler requires locked focus level and correctly adjusted working height to display a clear image.	Adjust the working height either manually or automatically until a clear image is displayed under the ruler.
6	Magnification figure on live image is not correct.	Objective mounted does not match selected objective in menu.	Select the correct objective in menu.
7	Image is too dark or too bright.	Insufficient light or camera settings are not optimal.	Turn on/adjust integrated light or optional ring light. Activate Auto-Exposure in menu. Then, adjust camera settings manually to your needs.
8	Unexpected freeze/shutdown.	Software crash or overheating.	Turn off the microscope, wait for a couple of minutes, turn it on again.
9	Image doesn't take up full width of monitor (Vignetting)	The edges of mounted objective is visible in the field of view.	Increase magnification level until vignette disappears.

Content

1 Safety

- 1.1 Intended use
- 1.2 Warnings

2 Assembling your microscope

- 2.1 Assembly
- 2.2 Connecting
- 2.3 Power on
- 2.4 Changing objectives
- 2.5 Using the magnetic ring light

3 Control options

- 3.1 Controller
- 3.2 Keyboard
- 3.3 Foot switch
- 3.4 Mouse
- 3.5 Open API

4 Menu

- 4.1 Graphical user interface
- 4.2 Menu features
 - 4.2.1 Light
 - 4.2.2 Applications
 - 4.2.2.1 Ruler app
 - 4.2.2.2 Measurement app
 - 4.2.3 Favourite shortcuts
 - 4.2.4 Settings
 - 4.2.4.1 Settings - General
 - 4.2.4.3 Settings - Network
 - 4.2.4.3 Settings - Camera
 - 4.2.5 Power controls

5 Other features

- 5.1 File share

6 Maintenance & support

- 6.1 Taking care of your microscope
- 6.2 Warranty
- 6.3 Troubleshooting
- 6.4 Support
- 6.5 Technical specifications
- 6.6 Declaration of conformity

7 Notes

6.4 Support

If you experience issues with your microscope, please check the troubleshooting section of this manual.

If you're still unable to solve the issue at hand, please contact the local partner that you bought the microscope from. You should only contact ZEISS directly if you did not buy the product from a local distributor. In this case, you can create a ticket using the support form on ZEISS' website:

<https://www.zeiss.com/microscopy/en/service-support/support/contact.html>

<https://portal.zeiss.com/>

When requesting support, either through a local partner or ZEISS, you should always state the model number and serial number of your microscope. You can find these information on the product label on the microscope.

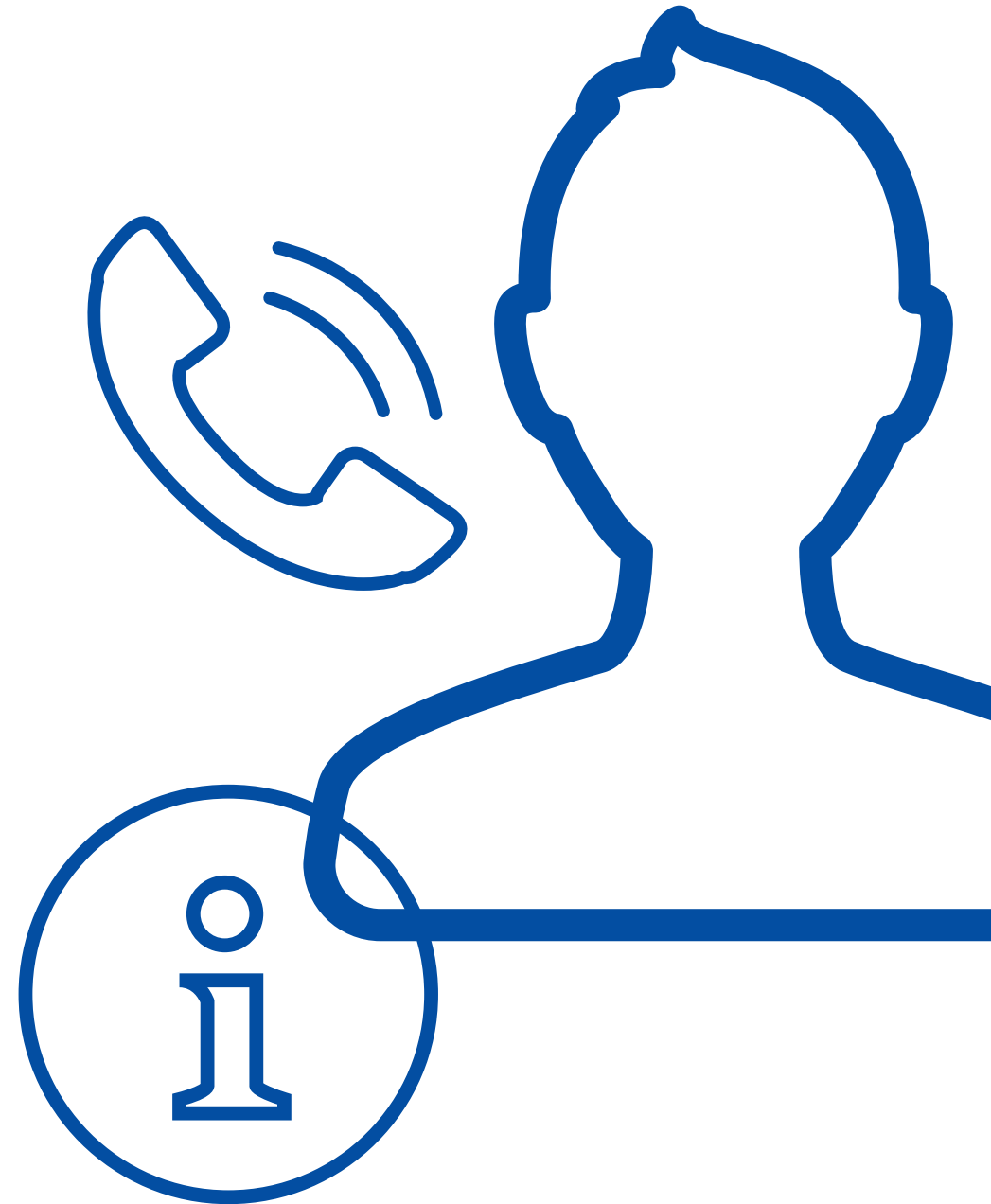

6.5 Technical specifications

Get to know the Smarzoom 100 in more detail by exploring the technical specifications listed below.

Camera specs

■ Camera resolution:	4K (3840x2160), 8.5MP @ 60/50/30Hz
■ Frame rate:	60 frames per second
■ Optical zoom:	25x
■ Video output:	HDMI
■ Aspect ratio:	16:9

Dimensions and weight

■ Height:	390 mm - 635 mm (15.35'' - 25'')
■ Width:	320 mm (12.60'')
■ Depth:	325 mm (12.80'')
■ Working depth:	370 mm (14.57'')
■ Weight:	10.8 kg (23.81 lbs)

Objective

Magnification range

Free working distance

Field of view

+3	1.6x - 40x	330 mm (12.99'')	16 mm - 353 mm (0.63'' - 13.90'')
+5	2.8x - 66x	200 mm (7.87'')	9.5 mm - 210 mm (0.37'' - 8.27'')
+10	5.4x - 130x	78 mm (3.07'')	4.8 mm - 86 mm (0.19'' - 3.39'')
+25	13.2x - 328x	34 mm (1.34'')	1.9 mm - 3.5 mm (0.07'' - 0.14'')

Content

1 Safety

- 1.1 Intended use
- 1.2 Warnings

2 Assembling your microscope

- 2.1 Assembly
- 2.2 Connecting
- 2.3 Power on
- 2.4 Changing objectives
- 2.5 Using the magnetic ring light

3 Control options

- 3.1 Controller
- 3.2 Keyboard
- 3.3 Foot switch
- 3.4 Mouse
- 3.5 Open API

4 Menu

- 4.1 Graphical user interface
- 4.2 Menu features
 - 4.2.1 Light
 - 4.2.2 Applications
 - 4.2.2.1 Ruler app
 - 4.2.2.2 Measurement app
 - 4.2.3 Favourite shortcuts
 - 4.2.4 Settings
 - 4.2.4.1 Settings - General
 - 4.2.4.3 Settings - Network
 - 4.2.4.3 Settings - Camera
 - 4.2.5 Power controls

5 Other features

- 5.1 File share

6 Maintenance & support

- 6.1 Taking care of your microscope
- 6.2 Warranty
- 6.3 Troubleshooting
- 6.4 Support
- 6.5 Technical specifications
- 6.6 Declaration of conformity

7 Notes

6.6 Declaration of conformity

Declaration of Conformity

Legal Manufacturer:

TAGARNO A/S
Finlandsvej 2
8700 Horsens
Denmark

PRODUCT

NAME	MODEL	DESCRIPTION
ZEISS Smartzoom 100	210011	Inspection Camera Unit

DIRECTIVES/STANDARDS

TAGARNO A/S hereby declares that the product listed above, complies with the following directives:

DIRECTIVE	
2014/35/EU	Low Voltage Directive
SI 2016 No. 1101	Electrical Equipment Safety Regulations (UK)
2014/30/EU	Electromagnetic Compatibility (EMC)
SI 2016 No. 1091	Electromagnetic Compatibility Regulations (UK)
2011/65/EU	Restriction of Hazardous Substances (RoHS)
SI 2012 No. 3032	Restriction of Hazardous Substances Regulations (UK)
2012/19/EU	Waste Electrical & Electronic Equipment (WEEE)

By conforming to the following harmonized standards and regulations:

STANDARD/REGULATION	
IEC 61326-1:2020	Class A / Industrial Electromagnetic Environment, Certified CB Scheme report
IEC 61010-1:2010 + AMD1:2016	Safety Requirements for Electrical Equipment for Measurement, Control, and Laboratory use, Certified CB Scheme report
EC 1907/2006	Registration, Evaluation, Authorisation & Restr. of Chemicals (REACH)
FCC	Part 15 Class A
IC	CAN ICES-3 (A)/NMB-3(A), Issue 7:2020

ISSUED BY

LEGAL MANUFACTURER	DATE (DD/MM-YYYY)
TAGARNO A/S	20/03-2025

SIGNATURE

Anders Ravnskjær Pedersen, Head of R&D



Questions?

If you have any questions about your microscope, don't hesitate to contact ZEISS.



authorized dealer:
Pulch + Lorenz microscopy
Neustrasse 43, 79312 Emmendingen
tel: 07641 9360 300
fax: 07641 9360 320
mail: kontakt@pulchlorenz.de
web: www.pulchlorenz.de

CONTACT US

Carl Zeiss Microscopy GmbH
Carl-Zeiss-Promenade 10
07745 Jena
Germany

<https://www.zeiss.com/microscopy/en/service-support/support/contact.html>

